

FITTING & OPERATING INSTRUCTIONS



T-MAX ELECTRIC WINCH MODEL DC3500

Part Nos: 12v Standard Drum 19461, Long Drum 19774
24v Standard Drum 19462, Long Drum 19773

CONFORMING TO
EN14492-1 Cranes – Power Driven Winches & Hoists – Part 1: Power Driven Winches

CONTENTS

INTRODUCTION	3
NEW EUROPEAN STANDARDS & BHW GROUP LIMITED	3
INSTALLER RESPONSIBILITY FOR CE COMPLIANCE	4
WINCH INFORMATION	
WINCH SPECIFICATIONS	5
WINCH PERFORMANCE	5
WINCH DIMENSIONS	6
WINCH LABELS	6
INSTALLATION	
WINCH MOUNTING	7
POWER SUPPLY FROM BATTERY TO SOLENOID PACK	7
POWER SUPPLY FROM SOLENOID TO WINCH MOTOR	7
ISOLATOR SWITCHES AND HEAVY DUTY FUSES	8
WANDERLEAD & WANDERLEAD EXTENSION OPTIONS	9
EMERGENCY STOP	10
TESTING	
TESTING THE WINCH	10
TRIALLING THE WINCH	10
WIRE ROPE	
WIRE ROPE INSTALLATION	10
OPERATING INSTRUCTIONS	
SAFETY PRECAUTIONS	11
RATING THE WINCH	12
OPERATING THE WINCH	13
FREESPOOLING & CAPACITIES	13
MAINTENANCE	13
NOTES ON BATTERIES	14
WINCH PARTS	
PARTS DRAWING & PART NUMBERS LIST	15
SOLENOID DRAWING & PARTS LIST	16
TROUBLESHOOTING	17
WARRANTY INFORMATION	18

INTRODUCTION

Thank you for purchasing a T-MAX DC3500 winch, one of a range of professional electric recovery winches available from the BHW Group Limited.

PLEASE READ THIS MANUAL CAREFULLY BEFORE INSTALLATION OR OPERATION OF THE WINCH

Those responsible for the installation and the operation of this winch must read and understand this manual. The first section deals with the installation requirements and the second section is for the user and provides information to ensure safe use of the winch.

This introduction also includes information on the European standard EN14492-1 for winches and the importance of correct product specification, installation and testing to ensure the essential Health and Safety requirements of the EC machinery directive are met.

PLEASE KEEP THIS OWNERS MANUAL WITH THE WINCH

EUROPEAN STANDARDS & BHW GROUP LIMITED

The harmonised European standard: EN14492-1 for power driven winches ensures conformity to essential Health and Safety requirements of the EN Machinery Directive. Conformity to these standards is the joint responsibility of the winch supplier, the installer and the company operating the machine.

Selecting the correct winch for the application is very important not only from the health and safety aspect, but also to maximise product life and value for money by reducing maintenance costs and vehicle down time.

BHW Group Limited products are fully compliant and carry a CE mark. A Declaration of Conformity is also supplied with each winch. BHW Group Limited aim to ensure the correct machine is supplied to suit the application and we welcome the opportunity of discussing the proposed application and offer advice. It will help us considerably if information regarding the maximum and average loads to be lifted or pulled - and approximate frequency of use can be provided.

This winch is to be used only for the purpose of vehicle recovery when fitted to equipment designed for the purpose, or the loading of wheeled vehicles upon bodies designed for the purpose, or used for a purpose specifically agreed with the BHW Group Limited.

For pulling winches the permissible standard of wire rope MBF** to winch rating must be a minimum 2:1 and the ratio of wire rope to mean drum diameter* a minimum of 10:1. This minimum standard is permitted because the running time for recovery winches is so short and the winch rarely sees maximum load. Whilst the requirements of this standard are very reduced compared to lifting winches it imposes a much higher standard of safety than those that before 2010. The new line pull ratings shown overleaf reflect this improved safety level.

Winches with the potential to apply forces over 1000kg must be load limited to prevent them applying loads above the safe working capacity. A slow burn fuse must be installed in the power supply cable. Please note that this does not meet requirements as a load limiter as it requires too much time to shut off the power to the winch.

Maximum wire rope length permissible on the drum must leave 1.5 x wire rope diameter from the top layer to drum flange.

The standard EN14492-1 considers all types of winches used for all applications and suggests guards are fitted if there is a chance an operator may become entangled. Personnel using vehicle-mounted winches are not generally close to the winch drum during recovery for this risk to occur. It is also important for the safety and ease of operation for the user to clearly see the wire rope wrapping onto the drum to ensure serious bunching and resulting jamming does not occur. Winches can be used in many different applications and the user or installer should carry out a risk assessment to determine any guarding that may be required.

In an application where hand tension is applied to the hook whilst the rope is being wound back on to the drum for storage there is a risk of the hand being pulled into the roller guide or drum. A short webbing strap should be used that is looped onto the hook to prevent the risk of this occurring (See picture on front of manual). These straps are supplied with wire rope provided with new winches and are available as a replacement part (No.9867) from BHW Group, or online at www.red-bhw.com.

* Mean drum diameter = the drum diameter plus the diameter of the wire rope. ** MBF = the Minimum Breaking Force of the wire rope.

INSTALLER RESPONSIBILITY FOR CE COMPLIANCE

1. Mount winch in accordance with instructions.

IMPORTANT NOTE: The direction of drum rotation during winching must be observed to ensure correct functioning of the overload device and the winch brake as these will only activate in the correct rotation of the drum as indicated on the label attached to the winch for pulling in.

2. Install an emergency stop switch in accordance with installation instructions included in this manual. (See Page 10). There are also options of BHW Emergency Stop systems listed in this section.
3. Install 10 mm 1960N/mm² grade, 6/36 wire core rope with minimum breaking load (MBL) of 7.12 Tonnes 69.8kN. Maximum rope length of 23m for standard drum, and 30m for long drum versions. This is the maximum rope length permissible to ensure compliance with EN14492-1 as this requires a 1.5 x wire rope diameter from the top layer to the drum flange.
4. Attach rope to the drum as per WIRE ROPE INSTALLATION INSTRUCTIONS. (Page 10).
5. Hook must have a safety latch and a minimum rated capacity of 2 tonnes. Use only high tensile grade 80 or 100. These hooks are rated and stamped for lifting and have a safety factor of 4:1. A 2 tonne hook has therefore a minimum yield of 2 x 4 = 8 tonnes. For pulling applications with a 2:1 factor of safety they are suitable for up to 4.0 tonne line pull.
6. Install a heavy duty fuse carrier as close to the battery as possible to prevent fire risk. For 12v winch this should be rated at 250 amp and for 24v use 100 amps. Details on heavy duty fuses can be found on Page 8.
7. Load test the winch following installation to check the integrity of the mounting.
8. You are also advised that adherence to the directive ISO4309:2004/2010 regarding care, installation and disposal of wire ropes also applies. (See section on Wire Ropes & Hooks).

FITTING INSTRUCTIONS

The T-MAX DC3500 has been built to a BHW Group specification to comply with EN 14492-1. This Winch is tough and will provide many years of reliable service if it is being used for the correct application. Like any professional equipment, it must be installed correctly in accordance with the installation instructions (Pages 7-10). The user must also adopt the correct procedures regarding operating instructions. (Pages 11-12).

Irrespective of how the winch is mounted it is important that adequate provision is made so that the load is transmitted into the body of the operating vehicle and then into the chassis.

IMPORTANT - WINCH ROTATION - PLEASE NOTE

The rotation of the drum when winching in must be correct as the load holding brake is only operational in one direction.

Viewed from the motor end, the drum rotation is clockwise when winding the rope onto the drum.

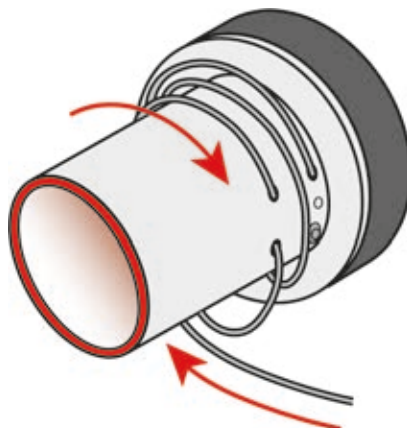

WINCH INFORMATION

WINCH SPECIFICATIONS

Model	T-MAX DC3500 Planetary Gear Electric Winch EN 14492-1 Compliant
Typical Uses	Car Transporters, Plant Moving Vehicles with GVW up to 7500kgf, Fire, Rescue and Utility Vehicles.
Construction	Die cast aluminium end housings with steel drum
Motor	Powerful 12v (4.8hp) or 24v (5.4hp) purpose made, series wound motor to ensure constant high power and torque. Roller bearings provide increased efficiency. Casings sealed against ingress with IP65 rating.
Gear Reduction	329:1 for 12v & 24v versions.
Electric Load Limiting Device	To comply with EN14492-1 and provide a 2:1 factor of safety for the wire rope.
Switching	Heavy duty, double acting solenoids. These can be mounted adjacent to the winch or on the winch tie bars with straps provided.
Wanderlead	Tough 2 way switch, hand held control with 3.7m lead. Other wanderleads / lengths available on request.
Freespool Clutch	Spring loaded sliding ring gear engaged and disengaged by rotating lever, on gear housing.
Drum Rotation	Clockwise viewed from motor end when pulling in.
Rope to Mean Drum Ratio	13:1 (Mean drum ratio)
Drum Dimensions	Standard Drum: 218mm length x 96mm diameter. Long Drum: 269mm length x 96mm diameter. Both versions have a 114mm flange diameter.
Recommended Wire Rope	10mm dia.(max.)1960N/mm ² grade 6 x 36 wire core construction with Minimum Breaking Load (MBL) 7.12 Tonne (69.8kN) must be used to comply with EN-14492-1 standards.
Recommended Rope Length	23m for standard drum, 30m for long drum.
Recommended Hook	2 tonne rated with safety latch. Use only high tensile grade 80 or 100 to comply with EN14492-1 standards.
Roller Guides	4 way roller guides.
Weight	Winch, complete with a mounting plate (optional), tension roller, roller guides and wire rope = 77kg.
Noise Level	72db
Ambient Temp. Operating Range	-20°C to 45°C

T-MAX DC3500 WINCH PERFORMANCE

		LAYER		
		1	2	3
Maximum Rated Line Pull by Layer*	kgf	3500	2935	2527
	kN	34	29	25
Cable Drum Capacity Cumulative by Layer (10mm Ø wire rope)	m	7	15	24

*By incorporating a snatch block in the line it is possible to double these capacities.

PERFORMANCE FIRST LAYER OF CABLE				
LINE PULL kgf	LINE SPEED (approx)		AMP DRAW (approx)	
	12v m/min	24v m/min	12v	24v
0	6.2	7.8	80	48
750	4	5.3	146	85
1500	3.1	4	184	106
2250	2.8	3.3	222	127
3000	2.4	3.4	261	148
3500	2.2	3.2	286	162

All figures are based on battery maintaining normal voltage.

WINCH INFORMATION

DIMENSIONS

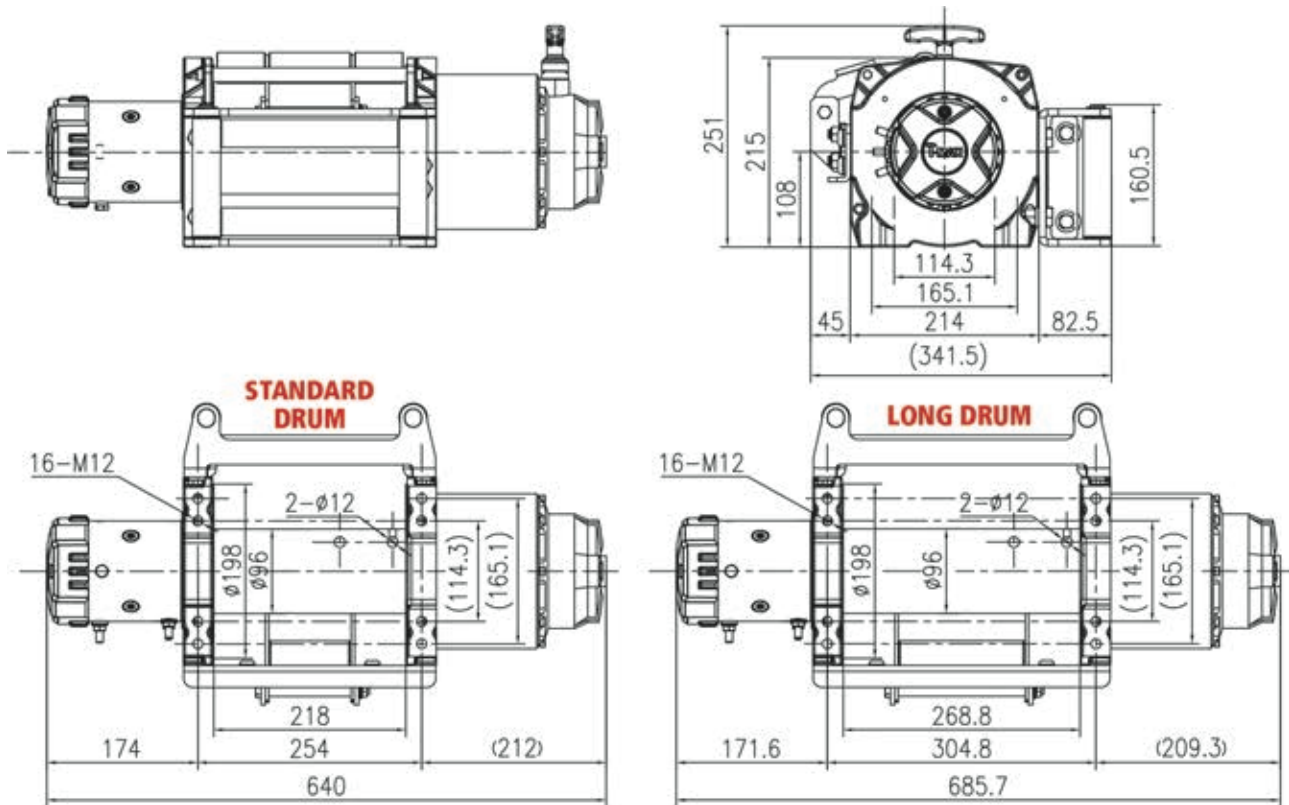

LABELS Information and warning labels are located as shown below.

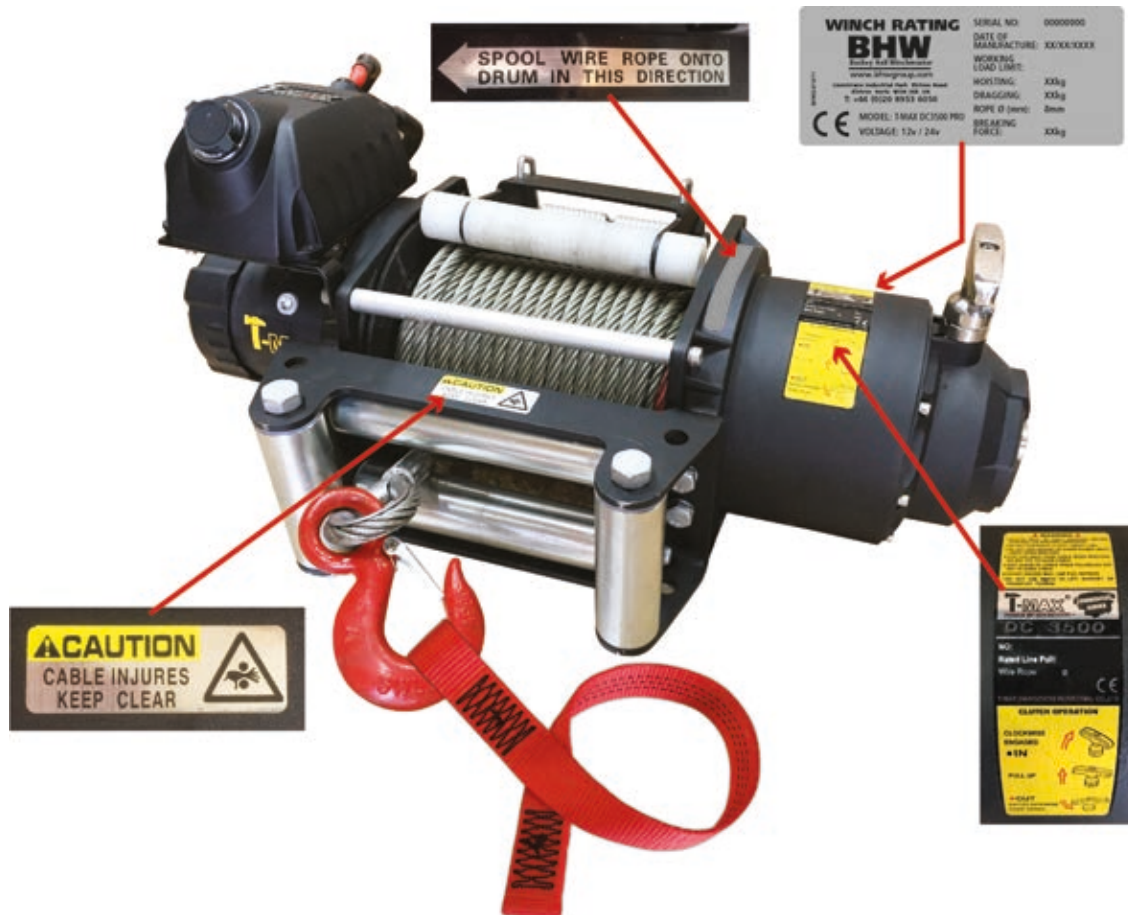

INSTALLATION

WINCH MOUNTING

The winch must be securely mounted on a flat surface so that the three major sections (the motor end, cable drum and gear housing end) are properly aligned. It is advisable to use the standard mounting plate available from BHW Group (Standard Drum: Part no.19899, Long Drum: Part no.19900) that includes pre-punched holes to ensure correct alignment.

The mounting surface must be flat (level support) within 0.38mm and sufficiently stiff to resist flexing.

Winch securing holes must be kept in alignment and not oversized.

FIXINGS

The bolts and fixings required for mounting the winch are as follows (*BZP = Bright Zinc Plated*):

8 no. M12 x 40mm H/T HEX set BZP	16 no. M12 Washers BZP
2 no. M12 x 25mm H/T HEX set BZP	10 no. M12 Spring Washers BZP
2 no. M12 Full Nut BZP	

In many applications, the body floor will be sandwiched between the mounting bracket and subframe sections.

ELECTRICAL CONNECTIONS & OPERATIONS

Always ensure the correct voltage corresponding to the chassis electrical system is used. If in doubt consult the dealer. For general advice on batteries please see section in the back of this manual. **Correct attention to the wiring of the winch is essential for correct and safe operation. See also notes on earthing on following page.**

POWER SUPPLY FROM BATTERY TO SOLENOID PACK

The power feeds must be rated at 300 amps for 12v and 170 amps for 24v winches. Cables from the batteries should be kept as short as possible to minimise any voltage drop. Recommended cable types are shown below. Available from BHW Group or online from www.red-bhw.com.

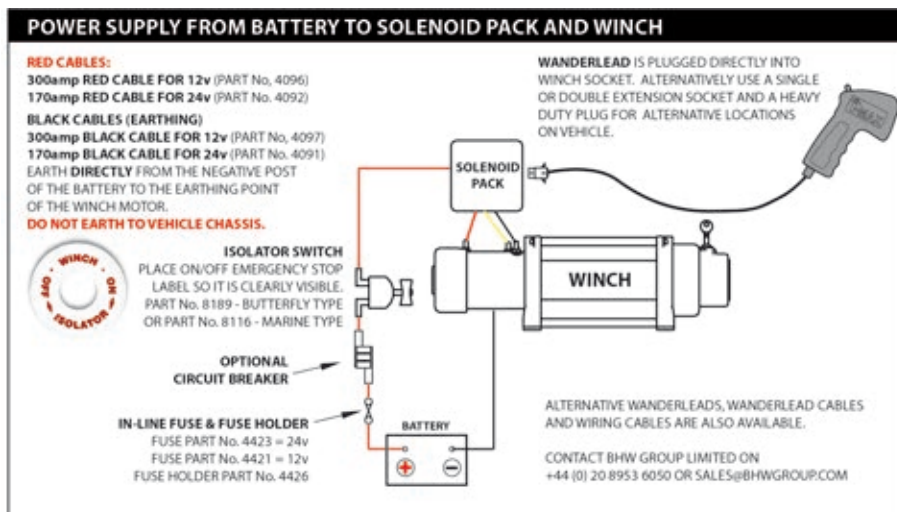

POWER SUPPLY FROM SOLENOID TO WINCH MOTOR

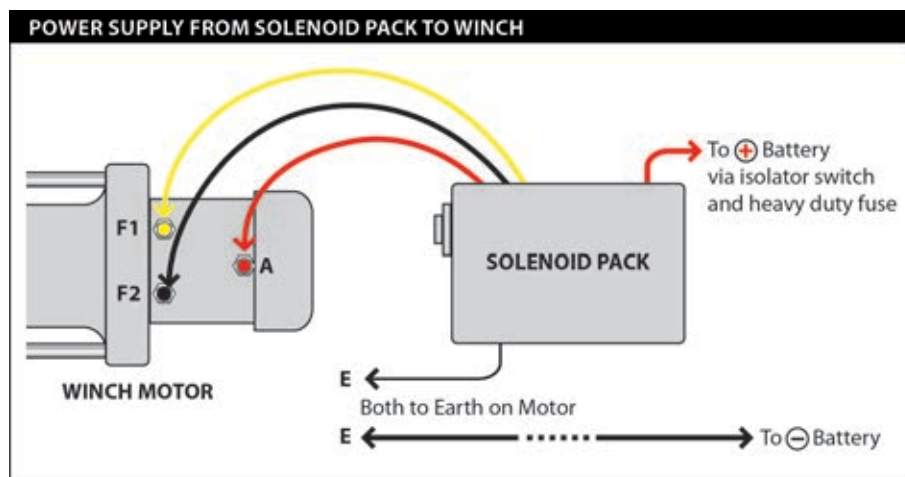

INSTALLATION

POWER SUPPLY FROM SOLENOID TO WINCH MOTOR

1. Short **RED** sleeved cable connects to red terminal (A) of the motor.
2. Short **YELLOW** sleeved cable connects to the yellow terminal (F1) of the motor.
3. Short **BLACK** sleeved cable connects to the black terminal (F2) on the motor.
4. Thin **BLACK** cable (e) connects to bottom terminal of the motor (earth).
5. Long **BLACK** cable (1.8m), one terminal (E) connecting to the bottom terminal (earth) of the motor, and the other terminal connecting to negative (-) terminal of battery.
6. Long **RED** cable positive (+) connect to positive terminal of battery via the isolator switch and heavy duty fuse.

Ensure that the correct voltage winch is fitted to match the vehicle electrical system.

IMPORTANT NOTE ON EARTHING

Always connect an earth wire **direct to the battery** and not just to the chassis. Not only will this prevent a voltage drop to the winch motor but also on modern chassis this is a requirement to prevent damage to the vehicle electrics and to also ensure a good earth return. The power feed and earth wire cables should be kept as short as possible to avoid voltage reduction to the motor as this will result in reduced puling force and a slower line speed.

ISOLATOR SWITCHES

A high amperage isolator switch must be fitted- either:

Marine type (left) - Part No. 8116.

Butterfly type (right) - Part No.8189.

Isolator switch kits include cable boots and rotation label.

Available from BHW Group or online at www.red-bhw.com

The isolator switch must be placed so that rotation on/off label is in a clearly visible position.



ISOLATOR SWITCH MUST BE TURNED OFF WHEN WINCH IS NOT BEING USED.

HEAVY DUTY FUSES (MEGAFUSE)

A fuse and fuse holder must be fitted in the positive feed cable as close to the battery as possible to prevent fire risk to the vehicle in the event of a short circuit in the supply cable.

These can be purchased separately from BHW Group Limited, or online at www.red-bhw.com.

These are not intended as a load limiting device. The response time to stop winching is too slow. A suitable load limiting device should be incorporated into the installation.



Please quote the following part numbers.

4422..... **250 amp** Megafuse (for **12v** winch)

4425..... **100 amp** Megafuse (for **24v** winch)

4426..... Megafuse Enclosure for above fuses

In some circumstances when the vehicle is involved in high usage with only short driving distances between winching operations, it will be necessary to fit an additional heavy duty battery wired in parallel with the vehicle battery and kept as close to the winch as possible.

It is also advisable to have the vehicle fitted with a heavy duty charging system and heavy duty batteries.

See notes on batteries (Page 14).

INSTALLATION – WANDERLEAD & WANDERLEAD EXTENSIONS

INSTALLING SUPPLIED WANDERLEAD

The wanderlead supplied with the winch is plugged into the socket on the solenoid box above the winch motor housing.



T-MAX DC3500 PRO ADDITIONAL EXTENSION LEAD

In addition to the wanderlead cable supplied with the T-MAX DC3500, there is a 3 metre extension lead available, that simply plugs into the socket on the winch and then on to the wanderlead cable. The extension lead (Part No. 19319) is available from the BHW Group, call +44 (0)20 8953 6050.

HEAVY DUTY FIXED EXTENSION LEAD

A heavy duty, fixed extension lead kit is also available (Part no. 19363).

The diagram below shows how the kit is assembled for use. It is important with this kind of installation on the vehicle that the heavy duty socket is securely bolted to the vehicle at a convenient point that will avoid damage and water ingress. Silicon waterproof sealant is recommended around all electrical connectors for added protection.

FIXED SINGLE EXTENSION WITH HEAVY DUTY SOCKET FOR T-MAX WINCHES

TO WIRE HEAVY DUTY SOCKET

- REMOVE TOP COVER OF HEAVY DUTY SOCKET.
- PASS CUT END OF THREE CORE CABLE THROUGH LOCKING NUT, RUBBER WASHER, CABLE GLAND AND ENTRY HOLE ON MOUNTING PLATE.
- LOOKING AT SOCKET FROM CABLE GLAND END, WITH MOUNTING PLATE FACING DOWN, CONNECT THREE CORE CABLE AS SHOWN BELOW.
- APPLY SILICONE SEALANT AROUND EDGES OF TOP COVER BEFORE IT IS SECURED IN PLACE TO PROVIDE WATER RESISTANCE.
- SCREW CABLE GLAND FITTING INTO SOCKET MOUNTING PLATE AND GENTLY TIGHTEN USING A SPANNER.
- SCREW LOCKING NUT WITH RUBBER WASHER INSIDE, ON TO CABLE GLAND AND GENTLY TIGHTEN AGAINST LOCK WASHER.

COMPLETE KIT PART No: 19363

ITEM	DESCRIPTION	PART No
1	3m CHROME PLUG & CABLE	19365
2	HEAVY DUTY SOCKET	7078
3	CABLE GLAND & LOCKING NUT	6067

The wanderlead supplied with the winch can then be re-wired with a heavy duty plug (Part no. 6473) or one of a range of heavy duty wanderleads available from BHW Group. Please call BHW Group on +44 (0)20 8953 6050 for options.

T-MAX WIRING COORDINATION FOR HEAVY DUTY SOCKET & PLUG

Wiring colours shown below are when seen from the cable gland end of either the socket or plug.

Heavy Duty Socket (Part no. 7078) Heavy Duty Plug (Part no. 6473)

Please note that the wiring for the heavy duty plug must agree with the colour coding used on the heavy duty socket for the winch direction to be correct when in use.

INSTALLATION

EMERGENCY STOP SYSTEM

It is a requirement under EN14492-1 and the Machinery Directive that all machines have Emergency Stops. Whilst BHW Group can offer a comprehensive range of Emergency Stop systems, it is ultimately the responsibility of the person installing the winch to carry out a risk assessment to decide and provide the Emergency Stop suitable for the application.

BHW Group Emergency Stop options include:

1. A heavy duty Emergency Stop circuit breaker button that is wired into the main power feed, that when activated cuts the power to the winch.
2. An additional solenoid, that utilises a diode and is energised as soon as either 'In' or 'Out' buttons on the wanderlead are activated. This diode ensures that the vehicle battery will not go flat if the operator forgets to turn off the winch isolator button after use. Emergency Stop circuit breaker button or buttons can be located in the appropriate position for the vehicle application. This system can work in conjunction with the BHW Group FM Connect radio remote system.
3. As No. 2 above but with an additional Emergency Stop circuit breaker button located on the wanderlead handset.
4. A complete control panel incorporating the directional solenoids, Emergency Stop and isolator switch.

The control system can then be mounted in the most suitable work area and comes with a full wiring harness.

Please contact BHW Group sales to discuss any of these options on +44 (0)20 8953 6050.

TESTING

After the installation is complete, a proof load test of 125% of the rated load should be carried out to ensure correct installation before the winch goes into service. To adjust the load limiter to provide the necessary force required see above under load limiting devices.

TO TRIAL THE WINCH: Turn on isolator switch, plug in wanderlead control. The winch can be powered both 'In, and 'Out'. The load should automatically hold safely when control button is released.

WIRE ROPE INSTALLATION

IMPORTANT NOTE: ROPE TENSIONER IS SPRING LOADED.

To avoid risk of injury or damage, care should be taken to safely secure and stop any movement of the rope tensioner to enable the loading of a wire rope on to the drum. Wear gloves and suitable protective clothing.

1. Safely secure wire rope tensioner AWAY from the drum to prevent any possibility of injury or damage.
2. Unwind the cable by rolling it out along the ground with the tapered end nearest to the winch. NEVER wind the cable straight onto the drum from a coil.
3. Rotate the rope drum under power until the rope fixing holes run vertically at the front of the winch.
4. Pass the rope end through the roller fairlead, UNDER the drum and back over the top of the drum to pass through the rope hole furthest way from the drum flange. Keep feeding the rope through to wrap around the drum FOUR TIMES and into the rope fixing hole nearest the drum flange.
5. Tighten the retaining screw ensuring that the rope end is flush with the exit of the hole and not protruding.
The securing end of the rope needs to be tight up inside the drum casing to avoid contact with the drive shaft that runs through the centre of the drum.
6. Feed back any excess slack to tighten the four wraps neatly on the drum.
7. Remove the locking pin from the cable tensioner to allow the rollers to rest on the rope. Note: This assembly is under tension. Special care should be taken to avoid trapping fingers, clothing etc.
8. Apply moderate tension to the rope. Take care to ensure the layers are neatly wrapped, as this will minimise damage to the lower layers of rope when a load is applied.

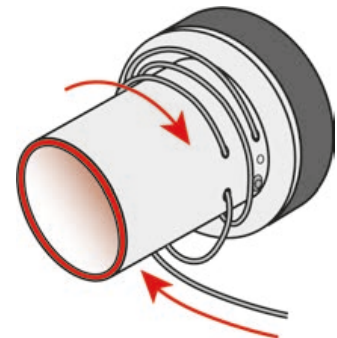

Diagram shows only two wraps illustrated for clarity.

OPERATING INSTRUCTIONS

SAFETY PRECAUTIONS

PLEASE READ THIS CAREFULLY BEFORE OPERATING THE WINCH.

It is important that you read and digest the information contained in this handbook. The winch is of the highest quality and has been designed to give a robust and efficient service for many years if care and attention are given at all times to correct, safe operation and maintenance.

Respect for a winch and common sense in its operation, will ensure complete safety and reliability. Do not underestimate the potential danger in winching operations. Be aware of the basic dangers so you can avoid risk of accidents and unnecessary damage to the winch or the vehicle / application.

THESE SAFETY PRECAUTIONS MUST BE OBSERVED AT ALL TIMES WHILST USING THE WINCH:

Keep yourself and others at a safe distance to the side of the wire rope when pulling under load.

Never step over, stand near or guide a rope under tension. Always use heavy duty gloves when handling the wire rope to protect against cuts or possible burns.

Take care of the wire rope. Check regularly for signs of damage or stretch in the form of broken strands or severe kinks along its length. If there are more than 10 strands broken in any 25mm of the rope's length then it will be significantly weakened and must therefore be replaced.

Wear and tear can be prevented by regular application of rope dressing available in aerosol form from your winch supplier. Oil and grease should never be used.

Always apply tension to the wire rope (using the safety hook webbing strap attached to the hook) to ensure that the wire rope is rewound neatly and evenly on to the drum. Loose coils or uneven wrapping are dangerous and can result in trapping or snatching when next used - and also damage to the wire rope or the winch.

These winches are fitted with a tension roller. It is very important when powering out under 'no load' to apply tension by hand to the wire rope, to prevent damage occurring to the rope due to any slack loops of cable developing on the winch drum. Wear gloves.

Do not drive the vehicle to pull a load on the winch wire rope, e.g. as a tow rope, any resulting shock load could break the rope or damage the winch.

If the winch is being operated at maximum capacity, drape a heavy blanket or coat over the wire rope, halfway along its length. The blanket will reduce the speed of a snapped rope.

When recovering a vehicle, the winch hook should be attached to the towing hitch, if available, or to a strap or chain around a chassis leg or cross member. **NEVER** anchor the winch hook onto bumpers, or shipping / transit anchorage.

Do not allow the load to 'snatch' during a pull, as this can momentarily double or even treble the load on the rope.

Try to position either your vehicle or the anchor point to ensure a straight pull. Use a snatch block if it is necessary to turn any corners with the rope.

When attaching the hook to the load, always double check that the hook is secure and the safety catch is fully closed. Remember that if the hook breaks away under tension, serious injury can result, as the hook will travel through the air at speed.

A minimum of five wraps of rope around the drum is recommended to hold the load.

NEVER hold the safety hook to rewind the winch – use the safety hook webbing strap provided.

OPERATING INSTRUCTIONS

RATING THE WINCH

The Winch rating on the T-MAX DC3500 refers to its maximum rated line pull, measured as the force being applied to the winch in a horizontal plane. As in the case of all winches, this refers to the first layer of rope on the drum.

In most cases, when the winch is being used, there is no way of accurately determining the exact pull being applied. It is important, however, to try and establish that it is within the working capacity of both the winch and wire rope and this can be done by considering the following formulae which applies for gradients up to an angle of 45°. For wheeled vehicles, the pull required to move the load equals:

$$\frac{W}{25} + \frac{(W \times \text{angle of gradient})}{60}$$

Where W = load in tonnes and angle of gradient is in degrees.

EXAMPLE: If W, the load of the vehicle is 2 tonnes and is being pulled up skids, which form a gradient of 15°, the force on the rope is:

$$\frac{2}{25} + \frac{(2 \times 15)}{60} = 0.08 + 0.50 = 0.58 \text{ tonne.}$$

Remember the winch pulling capacity reduces as the number of layers of wire rope increase on the drum.

If it is necessary to work beyond the limits of either the winch or wire rope, it is essential that a snatch block be employed, which will enable the line pull to be nearly doubled. If you should have any queries regarding the maximum load applied in a particular application, please do not hesitate to contact us and we will be pleased to offer our assistance.

TO OPERATE WINCH

Operator familiarisation:

Operators must firstly become familiar with the winch operating system with no loading applied.

Note the position of the power isolator switch and turn it on. All systems must by law include at least one emergency stop and these should be located in an easily accessible position and this should be noted. Plug in the wanderlead control and with the winch under no load but with hand tension applied through the strap attached to the hook power out and then in several times.

Now operate the freespool clutch to both see and feel the full engagement and disengagement position. With the winch disengaged freespool wire rope of the drum and then re-engage freespool.

When you are familiar with the operating features turn on the isolator and plug in the wanderlead control. The winch can be powered both in and out. The load is automatically held safely when control button is released.

The best way to become acquainted with how your winch operates is to make test runs. Plan your tests in advance. Remember that you hear your winch as well as see it operate. Come to recognise the sounds of a light steady pull, heavy pull, and sounds caused by load jerking or shifting. Gain confidence in operating your winch and its use will become second nature to you.

The uneven spooling of wire rope whilst pulling a load, is not a problem, unless there is a pile up of rope on one end of the drum. If this happens, reverse the winch to relieve the tension on the rope and move your anchor point further to the centre of the load. After the job is complete, you can unspool and rewind the wire rope neatly. Always switch off the power supply isolator switch after use and always use the webbing strap attached to the safety hook when rewinding rope back onto the drum to prevent potential injury to hands from the roller guide.

FREE SPOOLING

To release clutch, power out winch until tension is released from cable. Turn the control lever on the top of the casing and turn 90°. To re-engage, turn lever back through 90°. Ensure that handle is fully engaged before imposing any load on the winch.

The freespool clutch can also be operated by compressed air, by removing the plug on the end of the clutch and fitting a compressed air supply.

CAPACITIES

The T-MAX DC3500 winch is rated at 3500kg (34.3kN) and this refers to its safe working load, measured as the force being applied to the winch in a horizontal plane. As in the case of all winches, this refers to the first layer of rope on the drum.

MAINTENANCE

REGULAR MONTHLY MAINTENANCE

Externally:

The winch should be kept clean to prevent any build up of corrosion on external working parts.

Inspect roller guides for grooving and if excessive, rope life will be reduced.

Worn guides should be replaced to ensure rope is not damaged.

- Check winch for external damage.
- Check winch mounting for distortion and re-tighten mounting bolts if necessary.
- Operate free spool clutch mechanism to ensure correct operation, giving full engagement and disengagement.
- All external-moving parts should be lubricated with lightweight oil.
- All electrical connections and wiring should be inspected for loose connections, corrosion or fraying.
- Check the tie bars that hold the winch in alignment replace if bent or broken.
- Check the emergency STOP control to ensure it functions correctly by operating the winch and pushing the STOP button.

SPARES

If it becomes necessary to obtain replacement parts, refer to diagram and list shown on pages 19-20.

Please contact us quoting serial numbers if possible and model number.

BHW Group Limited reserve the right to change specifications without notice.

CARE OF A WIRE ROPE

NOTE: ISO 4309:2004/2010 – WIRE ROPES DIRECTIVE

ISO 4309:2004 / 2010 details guidelines for the care, installation, maintenance and examination of wire rope in service on winches, hoists and cranes, and enumerates the discard criteria to be applied to promote the safe use of the machinery.

It is important that these guidelines - for safe care, installation and ultimately disposal of wire ropes is strictly adhered to according to this directive.

It is most important that the wire rope is inspected on a regular basis, for kinks, flat spots, broken strands and other damage, and if necessary the damaged sections should be cut away and the rope reattached or completely replaced.

Check both the rope and the hook and replace under any of the following circumstances:

- 10 strands of rope or more broken with a space of 25mm (See fig. 1).
- Rope shows visible signs of wasting (See fig.2).
- Deformed or excessively corroded rope.
- Twisted rope.
- Bent rope.



A good habit is to rewind the rope onto the winch drum after it has been used, so that it is evenly layered. To do this, rewind keeping the rope under tension. Normally the load can be applied by hand.

Under no circumstances wrap the wire rope around the load being recovered and then attach the hook back on to the rope. This will result in serious rope damage or breakage. Always employ a chain or webbing strap from the hook to the load.

- Wire rope and hook must be replaced if damaged.
- If the winch is not being used on a regular basis it should be powered in and out from time to time to minimise corrosion of the internal motor components that may occur due to condensation. Energising the motor will generate heat, which will help dissipate any moisture.

WIRE ROPES ARE NOT COVERED BY WARRANTY.

NOTES ON BATTERIES

As a result of radical changes in vehicle battery design and performance that have taken place over recent years it is essential that the correct type are specified on new vehicles that will include an electric winch or other high electrical power consumer.

Heavy Duty ED3/VB3 rated should be specified as these are vibration proof and have 2.5mm thick plates compared to the standard 1.5mm. They also have glass wool separators, which reduces the leeching problem. The operating duty cycle for this class of battery is 14 starts compared to only 6 on a standard battery.

For extra heavy duty applications where high start up surges are required, Holchstrom Gel filled batteries should be specified which have a flat instead of declining rate of discharge. These offer up to a 40% increase of cold start performance for a battery of the same physical size.

Incorrect type will cause problems for vehicles using equipment requiring high DC Power consumption such as an electric winch, flashing beacons and work lights.

A standard amp hour rating is used for all batteries and this indicates the amperage available when a constant discharge is achieved over 20 hours. As an example a battery with an amp hour rating of 75 means the battery can carry a load of 3.75 amps for 20 hours.

Vehicle manufacturers' requirements have changed due to improved engine efficiency and many now require hundreds of amps for a few seconds for starting and to save space they demand small lightweight batteries. These batteries are designed to discharge around 15% of their total capacity and then recharge quickly from the alternator.

The duty cycle design criteria for vehicle batteries is to crank a cold engine for 10 seconds and then rest for 1 minute allowing the battery to recover and the starter motor to cool down. The engine would normally have started consuming equipment like a DC winch is operated for much longer periods of time with only short breaks and then recharged this is referred to as deep cycling. In winching applications the battery is continuously subjected to deep cycling and recharging this will result in premature loss of battery capacity.

The new generation of starter batteries are now light duty designed to retain 75% - 85% charge throughout their working life with a maximum duty cycle of 6 – 7 starts.

If batteries are used for winch or similar applications and suffers voltage drop, soft lead sulphate deposits may appear on the plates and separators. If left discharged for a period of around 70 hours the lead sulphate hardens and crystallises forming an insulation barrier preventing it from accepting a charge and effectively causing irreparable damage.

All popular traditional batteries leech between the plates when not in use particularly in warmer weather causing a self-discharge. In poor quality batteries this problem is worse.

24v systems using two 12v batteries of this type:- If one battery deteriorates and becomes weak it will resist charging and the stronger battery will take precedence. A voltage reading of 25-26v may be measured but under the very high load during winching this will reduce dramatically putting excessive strain on the good battery causing it to fail prematurely.

WINCH PARTS

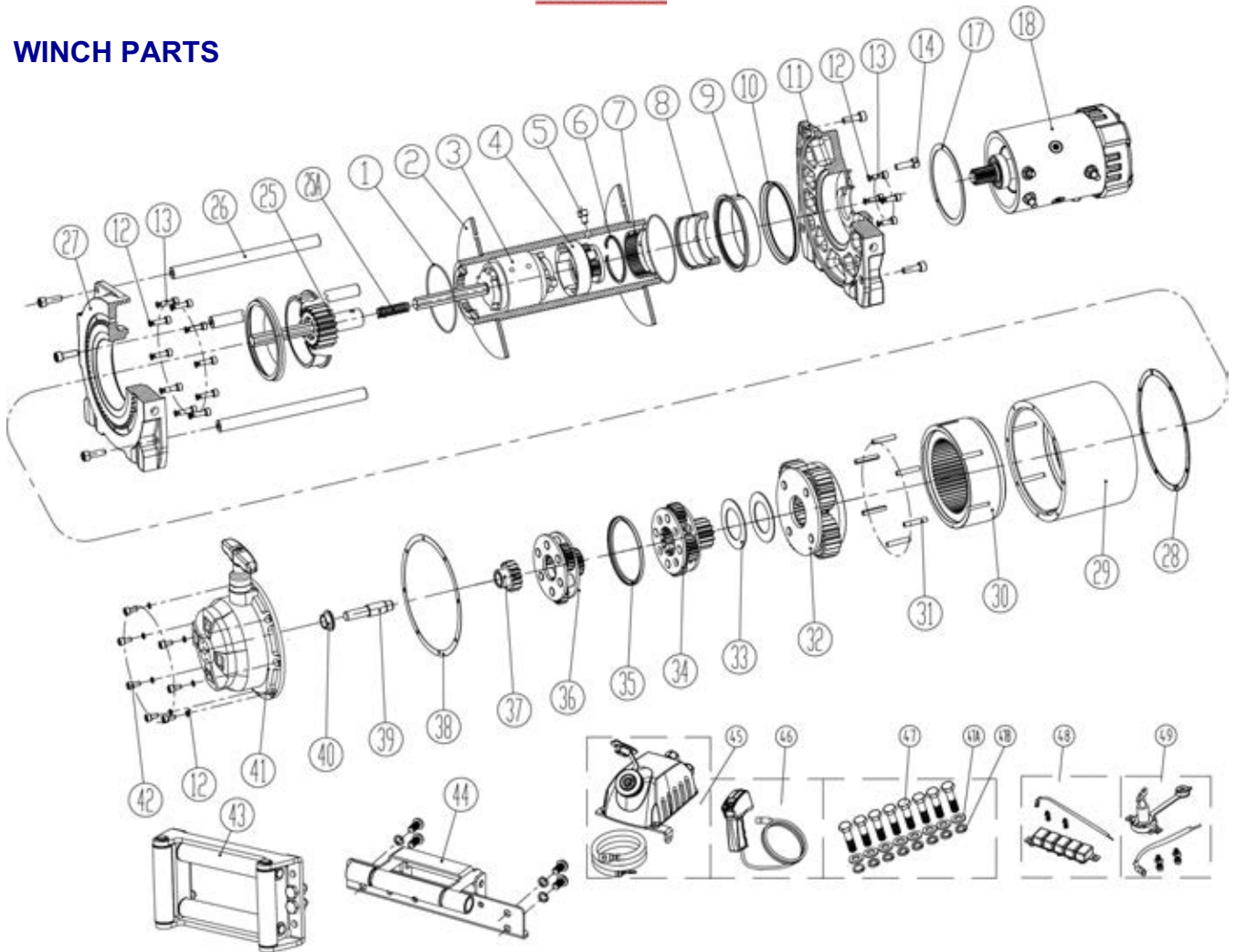

ITEM	Part No.	DESCRIPTION	Qty
1	19632	O Sealing Ring 90 x 2.65	2
2	19633	Drum Assembly (Standard)	1
2	19770	Drum Assembly (Long)	1
3	19675	Brake Assembly	1
4	19635	XRC15 Gear Carrier Assembly - Input (Long)	1
5	19636	Screw M10 x 12	1
6	19637	Retaining Ring	1
7	19638	Long Inner Gear	1
8	19639	Fixing Ring	1
9	19667	Anti-Dust Nylon Bearing	2
10	19668	Anti-Dust Ring	2
11	19669	XRC IP Motor Base	1
12	19640	Spring Washer 5	21
13	19641	Screw M5 x 20	14
14	19642	Screw M8 x 25	4
17	19670	Motor End Sealing Ring	2
18	19671	12v Motor	1
18	19672	24v Motor	1
25	19644	4-Stage Clutch Spline Assembly	1
25A	19643	Clutch Spring	1
26	19673	15000 Long Tie Bar	2
26	19676	15000 Short Tie Bar	1
27	19674	IP Big Gearbox Base	1
28	19645	15000 Anti-Leak Washer (10 holes)	1
29	19646	58 Tooth Long Inner Gear	1

ITEM	Part No.	DESCRIPTION	Qty
30	19647	Clutch Gear	1
31	19648	Elastic Cylindrical Pins 6 x 35	6
32	19649	Gear Carrier Assembly - Output	1
33	19650	Barrier Gasket	2
34	19651	CEW12/9 Gear Carrier Assy - Intermediate II	1
35	19652	Adjust Washer	1
36	19653	CEW9 Gear Carrier Assy - Intermediate I	1
37	19654	19 Tooth Sun Gear II	1
38	19658	170-8 Anti-Leak Ring for gearbox	1
39	19657	4-Stage Clutch Pin	1
40	19656	Plastic Bearing	1
41	19655	Gearbox Cover	1
42	19642	Screw M5 x 14	7
43	19659	Roller Fairlead Assembly (Standard Drum)	1
43	19771	Roller Fairlead Assembly (Long Drum)	1
44	19660	Wire Rope Tensioner (Standard Drum)	1
44	19772	Wire Rope Tensioner (Long Drum)	1
45	21835	12v Control Box Assembly	1
45	21838	24v Control Box Assembly	1
46	19663	Handheld Remote Controller	1
47	19664	High Strength Bolt M12 x 40	8
47A	19665	Big Washer 12	8
47B	19666	Spring Washer 12	8
48	19765	200A Over Current Protectors	1
49	19766	Emergency Stop / Isolator	1

SOLENOIDS - Information

The T-MAX solenoid for this winch (Part nos. 21835 = 12v, 21838 = 24v).

The diagram shown below is for construction information purposes only and components are numbered for reference purposes.

Please note that replacement solenoids are sold as complete units.

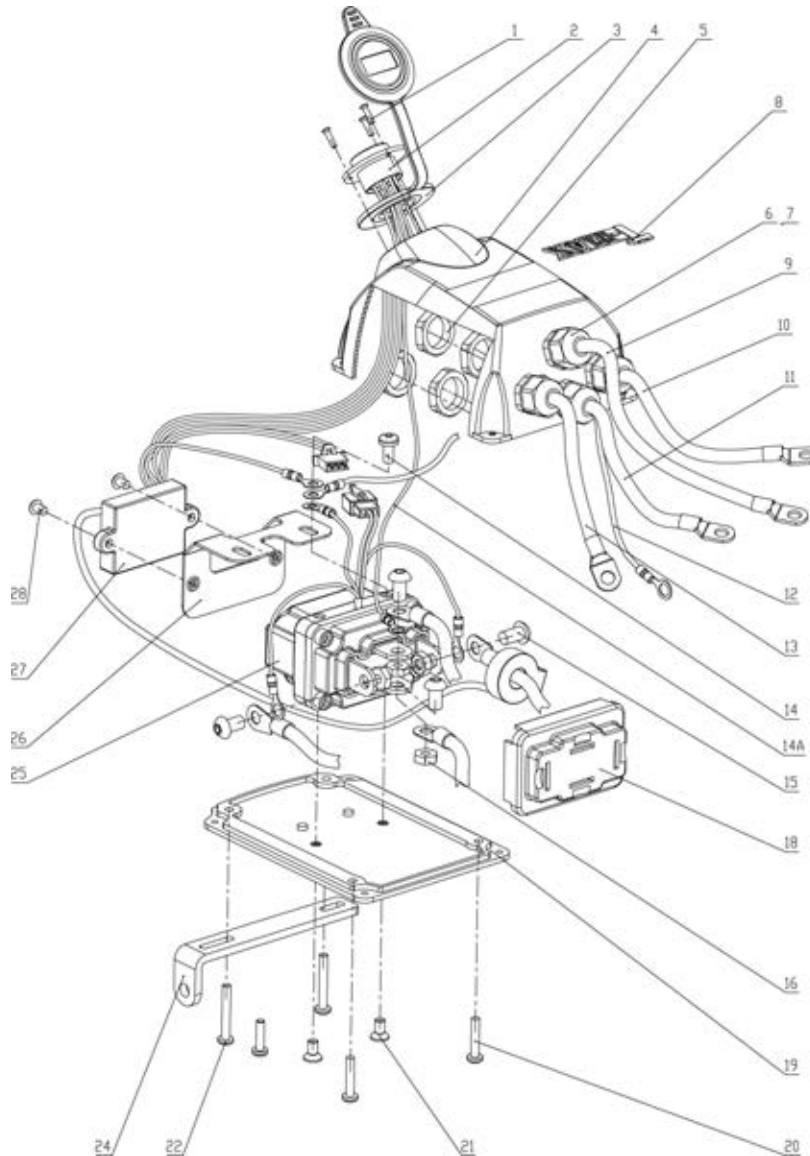

WANDERLEAD EXTENSION

3m extension to wanderlead: Part No. 19319

Please contact sales at BHW Group on +44 (0)208 953 6050



TROUBLE SHOOTING

CONDITION	POSSIBLE CAUSES	CORRECTIONS
Clutch inoperative and will not rotate.	Dry gearbox and mechanism.	Strip gearbox clean and re-grease.
Cable drum will not freespool	1) Winch not mounted squarely, causing end bearings to bind drum 2) Drum bearing dry	Check mounting, refer to winch mounting, page 7 Strip clean and grease
Winch will not hold the load	1) Excessive load. 2) Worn or damaged brake	Reduce the load or double line using snatchblock Repair or replace brake
Motor runs in one direction only	1) Inoperative solenoid or stuck solenoid 1) Broken wire or bad connection 2) Load limit switch malfunctioning (if fitted)	Jar solenoid to free contacts. Check by applying 12 volts to coil terminal (it should make an audible click when energised) Check for loose connection on wanderlead control Replace load limiter and reset
Motor runs extremely hot	1) Long running period at high loading. 2) Damaged motor 3) Damaged brake	Cooling-off periods are essential to prevent overheating Replace motor Replace brake
Winch runs in reverse	1) Motor wires reversed 2) Solenoids wired incorrectly	Check wiring Recheck wiring
Motor will not operate	1) Isolator switch not turned on 2) Fuse has blown 3) Break in power lead or extension socket 4) Inoperative solenoid or stuck solenoid 5) Inoperative motor 6) Loose connections 7) Emergency stop button depressed	Turn on isolator switch Replace fuse Repair or replace wiring Jar solenoid to free contacts. Check by applying 12volts to coil terminal (it should make an audible click when energised). If there is no click fit new solenoid If solenoids operate, check for voltage at armature post, replace motor Check all power lead connections are tight Check emergency stop and if depressed, release
Motor runs but with insufficient power or line speed	1) Weak Battery 2) Battery to winch power lead too long creating voltage drop 3) Poor battery condition 4) Poor earth connection 5) Damaged brake 6) Poor isolator switch condition	Recharge or replace battery. Check charging system Check correct amperage cable and/or reduce length Check battery terminals for corrosion. Clean as required Check and clean connection Cable should earth to battery not chassis. Repair or replace brake Repair or replace isolator switch
Motor runs but drum doesn't turn	1) Clutch not engaged 2) Drive shaft damage	Engage clutch Repair or replace drive shaft

WARRANTY

BHW GROUP LIMITED warrants each new winch and ancillary equipment supplied against factory defects in material and workmanship for one year from date of purchase.

The responsibility for removing the winch or ancillary equipment is the owner's together with its return, transportation prepaid to BHW Group Limited.

BHW Group Limited will, under this Warranty, without charge repair or replace at its option, parts, which on inspection are deemed to be defective. The loss of use of the produce, loss of time, inconvenience, commercial loss or consequential damages are not covered.

Warranty does not apply where the product has been tampered with or altered in any way, or where the serial number or date stamp has been defaced, altered or removed, or if in the view of BHW Group Limited the damage or failure occurred from misuse, negligence or accident.

THIS WARRANTY EXCLUDES THE WIRE ROPE

BHW Group Limited reserve the right to change the design of any product without assuming any obligation to modify any product previously supplied.

BHW Group Limited reserve the right to change the design of any product without assuming any obligation to modify any product previously supplied. Fitted vehicles or equipment returned under warranty should be sent to BHW Group Limited service department at the address indicated below, with full name and address of sender, and a statement detailing the defect.



Service Department
Lismirrane Industrial Park
Elstree Road
Elstree Herts WD6 3EE

Telephone: +44 (0)20 8953 6050

Email: sales@bhwgroup.com

Website: www.bhwgroup.com

T-MAX DC3500 VOLTAGE

SERIAL NUMBER.....

DATE OF PURCHASE.....