

## FITTING & OPERATING INSTRUCTIONS

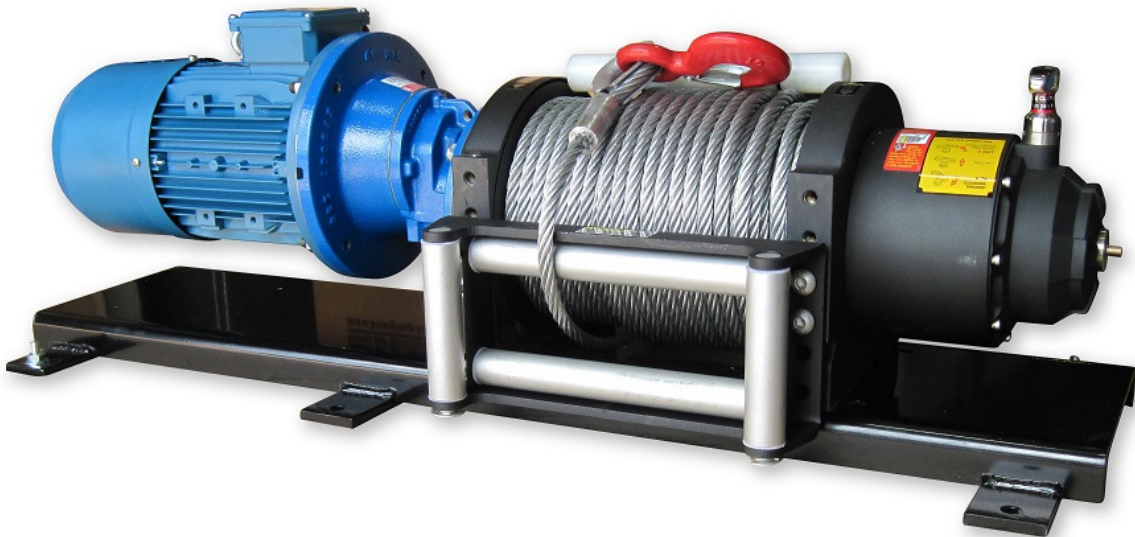

### AC2000 MK4 SERIES AC ELECTRIC WINCH

2000kg (19.6kN) 240v x 1ph / 415v x 3ph  
ITEM #20282 / ITEM #20283 / ITEM #20284

CONFORMING TO  
EN14492-1 Cranes – Power driven winches and hoists – Part 1: Power Driven Winches

## **CONTENTS**

<b>INTRODUCTION</b>	3
<b>STANDARDS &amp; BHW GROUP LIMITED</b>	3
<b>INSTALLER RESPONSIBILITY FOR UKCA &amp; CE COMPLIANCE</b>	4
<b>WINCH INFORMATION</b>	
WINCH SPECIFICATIONS	5
WINCH PERFORMANCE	6
WINCH DIMENSIONS	6
WINCH LABELS	7
<b>INSTALLATION</b>	
GENERAL INSTALLATION NOTES	8
WINCH MOUNTING	8
ELECTRICAL INSTALLATION	9
EMERGENCY STOP SYSTEMS	9
PENDANT CONTROLS	10
LOW VOLTAGE CONTROLS	11-12
WIRING DIAGRAMS	13-17
OPERATIONAL OVERVIEW	17
WIRE ROPE INSTALLATION	18
<b>OPERATING INSTRUCTIONS</b>	
SAFETY PRECAUTIONS	19
RATING THE WINCH	20
OPERATING THE WINCH	21
FREESPOOLING AND CAPACITIES	21
LOAD TESTING	21
<b>MAINTENANCE</b>	
MONTHLY MAINTENANCE	22
ANNUAL MAINTENANCE	22
CARE OF THE WIRE ROPE	22
<b>WINCH PARTS</b>	
PARTS DIAGRAM	23
PARTS LIST	23
<b>TROUBLESHOOTING</b>	24
<b>WARRANTY</b>	25

## INTRODUCTION

Thank you for purchasing an AC2000 Mk4 winch, one of a range of professional AC winches available from the BHW Group Limited.

These winches are designed for **pulling applications only** and therefore should never be used for any type of lifting application.

### PLEASE READ THIS MANUAL CAREFULLY BEFORE INSTALLATION OR OPERATION OF THE WINCH

Those responsible for the installation and the operation of this winch must read and understand this manual. The first section deals with the installation requirements and the second section is for the user and provides information to ensure safe use of the winch.

This introduction also includes information on the British standard BN/EN14492-1 for winches and the importance of correct product specification, installation and testing to ensure the essential Health and Safety requirements of both the EC machinery directive and the Health and Safety Act 1974 are met.

## STANDARDS & BHW GROUP LIMITED

The BS EN14492-1 for power driven winches ensures conformity to both the essential Health and Safety requirements of the UK Health and Safety Act 1994 and the EN Machinery Directive. Conformity to these standards is the joint responsibility of the winch supplier, the installer and the company operating the machine.

Selecting the correct winch for the application is very important not only from the health and safety aspect, but also to maximise product life and value for money by reducing maintenance costs and vehicle down time.

BHW Group Limited products are fully compliant and carry a UKCA/CE mark. A Declaration of Conformity is also supplied with each winch. BHW Group Limited aim to ensure the correct machine is supplied to suit the application and we welcome the opportunity of discussing the proposed application and offer advice. It will help us considerably if information regarding the maximum and average loads to be lifted or pulled - and approximate frequency of use can be provided.

A pulling winch such as the AC2000 Mk4, is usually operated intermittently and the factor of safety in the wire rope is generally 3:1 and a wire rope to mean drum diameter\* of not less than 10:1. The maximum length of wire rope on the drum is determined by the guideline that when all the rope is wound on, a distance of 1.5 x the wire rope diameter should be remaining from the top layer to the outer edge of the drum flange.

Winches with the potential to apply forces over 1000kg must be load limited to prevent them applying loads above the safe working capacity.

Maximum wire rope length permissible on the drum must leave 1.5 x wire rope diameter from the top layer to drum flange.

The standard BS EN14492-1 considers all types of winches used for all applications and suggests guards are fitted if there is a chance an operator may become entangled. It is also important for the safety and ease of operation for the user to clearly see the wire rope wrapping onto the drum to ensure serious bunching and resulting jamming does not occur. Winches can be used in many different applications and the user or installer should carry out a risk assessment to determine any guarding that may be required.

In an application where hand tension is applied to the hook whilst the rope is being wound back on to the drum for storage there is a risk of the hand being pulled into the roller guide or drum. A short webbing strap should be used that is looped onto the hook to prevent the risk of this occurring (See picture on front of manual). These straps are supplied with wire rope provided with new winches and are available as a replacement part (No.9867) from BHW Group, call +44 (0)1482 223 663.

\* Mean drum diameter = the drum diameter plus the diameter of the wire rope. \*\* MBF = the Minimum Breaking Force of the wire rope.

## INSTALLER RESPONSIBILITY FOR UKCA & CE COMPLIANCE



1. Mount winch in accordance with instructions.
2. Install 10mm 1960N/mm<sup>2</sup> grade, 6/36 wire core rope with minimum breaking strain of 63.9kN (6370kg) Maximum rope length of 50m x 4 layers. This is the maximum rope length permissible to ensure compliance with BS EN14492-1 as this requires a 1.5 x wire rope diameter from the top layer to the drum flange.
3. Attach rope to the drum as per WIRE ROPE INSTALLATION INSTRUCTIONS. (Page 15).
4. Hook must have either a safety latch or be self-latching to ensure that the load is secure during a pulling operation. Hooks should be grade 80 or 100 and must have rated capacity and identification markings on clearly labeled, to comply with BS EN14492-1 standards.  
All hooks are rated for lifting at a safety factor of 4:1.  
Example: A 1.5 Tonne hook has therefore a maximum yield of  $1.5 \times 4 = 6$  Tonne.  
For pulling applications there should be a factor of safety standard of 2:1 which will give you a working capacity of 3 Tonne on a 1.5 Tonne hook. 10mm  $\varnothing$  wire ropes should have a rated hook at 2 tonne.
5. Load test the winch following installation to check the integrity of the mounting and adjust to ensure the correct load setting is achieved. See Page 17.

## WINCH INFORMATION

### WINCH SPECIFICATIONS

<b>Model:</b>	<b>AC2000 Mk4 AC Winch – 1ph (240v) or 3ph (415v) 2000kg (19.6kN)</b> <b>For winch variants please see following page.</b> <b>BS EN14492-1 Compliant.</b>
<b>Construction:</b>	Die cast aluminium end housings with steel drum
<b>Motor:</b>	Induction braked for all models
<b>Gearbox:</b>	4 stage planetary <b>Gear</b>
<b>Reduction:</b>	See following page for variants
<b>Switching:</b>	240v, single phase; or 415v, 3 phase via reversing contractors in the low voltage controls
<b>Wanderlead:</b>	Low voltage, 3 button hand held control with 3m lead. (Other lengths available on request)
<b>Freespool Clutch:</b>	Rotating handle gear housing to disengage clutch.
<b>Drum Rotation:</b>	Clockwise viewed from motor end when pulling in.
<b>Recommended Wire Rope:</b>	1960N/mm <sup>2</sup> grade 6 x 36 wire core construction with 6370kg (63.4kN) minimum breaking strain must be used to comply with BS EN14492-1 standards. For Rope Ø, length and MBL see following page.
<b>Recommended Hook:</b>	2 tonne (10mm rope Ø) rated with safety latch according to wire rope sizes (shown in brackets). Use only high tensile grade 80 or 100 to comply with BS EN14492-1 standards.
<b>Approximate Weight:</b>	Average kit weight approximately 130kg.
<b>Rope to Mean Drum Ratio: Drum</b>	12.9:1
<b>Dimensions: Recommende</b>	119mm Ø x 267mm length. 240mm flange.
<b>Storage Capacity: Roller Guides</b>	See section on wire ropes on following page.
<b>(optional): Tension Roller</b>	Heavy duty 4-way commercial type.
<b>(optional):</b>	Spring loaded roller tensioner to assist wrapping.
<b>Skid frames / mounting plates:</b>	Available for all models.
<b>Noise Level:</b>	85db.
<b>Ambient Temp. Operating Range:</b>	-28°C to 60°C
<b>Typical Uses:</b>	<ul style="list-style-type: none"> <li>▪ General industrial recovery work.</li> <li>▪ Production line – movement of loads.</li> <li>▪ Servicing departments – Recovery of machinery for inspection or service.</li> <li>▪ Installation – Positioning and dragging movement of new equipment.</li> </ul>
<b>Winch Performances:</b>	See specifications on following page

## WINCH INFORMATION

### WINCH PERFORMANCE

AC2000 Mk4 WINCH VARIANTS																		
No.	Voltage	Rated Load per Layer (kg. / kN)				Line speed m/min				Wire rope			Rope Length m/layer				Motor Amps	Gear Ratio
		1st	2nd	3rd	4th	1st	2nd	3rd	4th	Ø mm	Length	MBL	1st	2nd	3rd	4th		
20282	240v	2000/19.6	1732/17	1527/15	1365/13.4	3.7	4.3	4.9	5.5	10	50m	6370kg	10.2	21.6	32	47.3	10.8	304.2:1
20283	415v	2000/19.6	1732/17	1527/15	1365/13.4	3.6	4.3	4.9	5.2	10	50m	6370kg	10.2	21.6	32	47.3	4.8	164.4:1
20284	415v	2000/19.6	1732/17	1527/15	1365/13.4	7	8.1	9.2	10.4	10	50m	6370kg	10.2	21.6	32	47.3	7.8	164.4:1

### DIMENSIONS

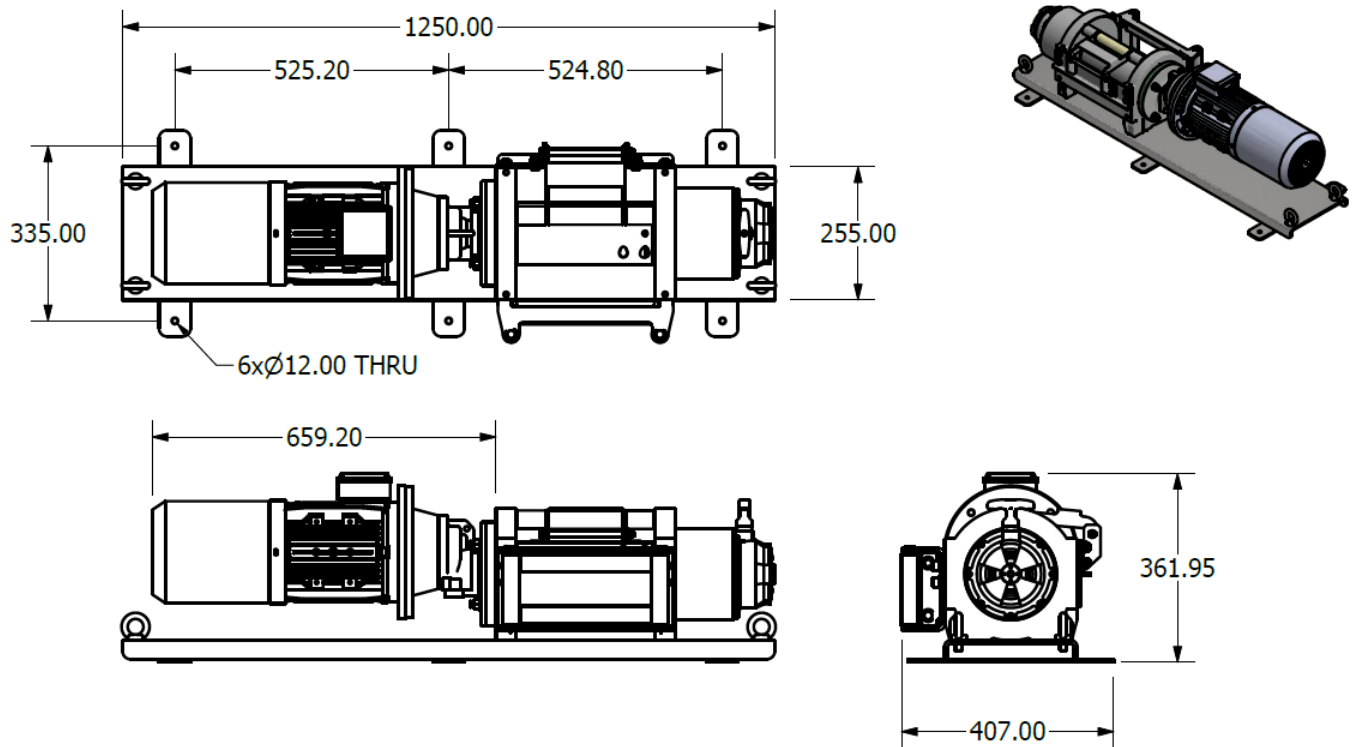

Data shown is approximate and intended as a guide only.

## WINCH INFORMATION

### WINCH LABELS

**LABELS** Information and warning labels are located as shown below



## INSTALLATION

### GENERAL INSTALLATION NOTES

The AC2000 Mk4 series has been built to a BHW Group specification to comply with BS EN14492-1. These winches are tough and will provide many years of reliable service if being used for the correct application.

Like all machines they must be installed correctly in accordance with these fitting instructions (Pages 8-15) and subsequently the user must also adopt the correct procedures as those included in the section headed operating instructions. (Pages 16-18).

Before installing the winch, it is important to work out what load bearing may be put into the adjacent area. A suitable support must be fitted across the area to support the load. You are advised to consult a qualified builder or structural engineer to determine these factors.

It is also important to fit a fused isolation switch in the power supply line at the point of operation. A lockable switch may be deemed necessary if there is a risk of unauthorised personnel gaining access to the working area.

### WINCH MOUNTING

The winch must be securely mounted on a flat surface so that the three major sections (the motor end, cable drum and gear housing end) are properly aligned. It is advisable to use the standard mounting bracket for this winch that includes pre-punched holes to ensure correct alignment.

The mounting surface must be flat (level support) within 0.38mm and sufficiently stiff to resist flexing. Winch securing holes must be kept in alignment and not oversized.

Using the standard mounting bracket with the winch pre-fitted, install angle or channel sections between the first and second body cross bearer positioned so the centreline of the winch drum is on the centreline of the body.

### FIXINGS

#### **Winch to Heavy Duty Mounting Plate**

8 no. M12 x 40mm H/T HEX set BZP  
8 no. M12 Washer Flat BZP  
8 no. M12 Washer Spring

#### **Roller Guide to Winch**

Supplied with roller guide.

#### **Tension Roller to Winch**

Supplied with tension roller.

#### **Tie Bar to Winch**

4 no. M12 x 25mm H/T HEX set BZP.  
4 no. M12 Washer Spring BZP

*(BZP = Bright Zinc Plated)*

**Warning! Never lift the winch via its motor or gearbox, doing so will cause damage use lifting point on mount plate as provided.**



## INSTALLATION

### ELECTRICAL CONNECTIONS & OPERATIONS

Always ensure the correct voltage corresponding to the winch electrical system is used. Electrical installation should be carried out by a qualified electrician.

***Correct attention to the wiring of the winch is essential for correct functioning and safety. Any electrical inspections or repairs must be carried out by qualified technicians.***



### ELECTRICAL SAFETY

**According to the Health and Safety Executive, each year there are approximately 1000 work accidents involving electric shock or burns. Around 30 of these are usually fatal.**

**Non-fatal shocks can cause severe or even permanent injury. Improperly installed electrical equipment can also cause related accidents in the workplace.**

**Electricity at Work Regulations (1989) requires adequate precautions to be taken against the risk of death or injury from electricity during work, at or near electrical installations.**

**Power supply must be provided to the correct voltage specification** – power to be provided in all cases (whether 1ph or 3ph) at 50Hz, with neutral and earth rated according to the winch motor involved.

Please determine the electrical requirements for the application prior to any work as insufficient installation standards will result in damage to the winch and possibly put operatives in danger.

The winch is directly powered by the mains supply in the work area. A suitable fused isolator switch must be installed in the incoming power supply to provide additional facilities to shut down the power to the winch, or problems due to an overload of the winch.

A test weight should be fitted to the wire rope before setting amp limit switch parameters, this will allow final adjustments and tests to be carried out reducing the possibility of damage to the winch.

### EMERGENCY STOP SYSTEMS

It is a requirement under BS EN14492-1 and the Machinery Directive that all machines have Emergency Stops. You are advised that additional emergency stop facilities and adequate isolation / fusing facilities should be built into the installation of an AC2000 Mk4 series **in addition** to the standard Emergency Stop supplied as part of the wanderlead control.

BHW Group can offer a comprehensive range of Emergency Stop and isolator equipment as required. It is ultimately the responsibility of the person installing the winch to carry out a risk assessment to decide and provide additional Emergency Stops, isolators and fuse restriction suitable for the application.

Please contact BHW Group Ltd sales for Emergency Stop and Isolator options on +44 (0)1482 223 663.

## INSTALLATION

### PENDANT CONTROLS

The AC2000 Mk4 series of winches are supplied as standard with a 3.0m wanderlead pendant which operates on low voltage for all models.

BHW Group emphasise that the supplied pendant / wanderlead control must be used on the AC2000 Mk4 series and fitted by a fully qualified installer to ensure correct installation and operation of the winch.

Failure to adhere to these requirements can cause damage to equipment or personal injury - and will also invalidate the warranty of the product.



Above are shown examples of the 3ph and 1ph low voltage systems supplied by BHW Group Limited. Please refer to the wiring diagrams that follow in this manual for installation guidelines.

## INSTALLATION

### TYPICAL LAYOUT – Low Voltage Controls



### PART IDENTIFICATION – Low Voltage Controls



Isolator contact



Reversing contactors with  
mechanical interlock



Transformer input 240v 1ph  
or 415v 3ph - Output 24vac

## INSTALLATION

### PART IDENTIFICATION – Low Voltage Controls

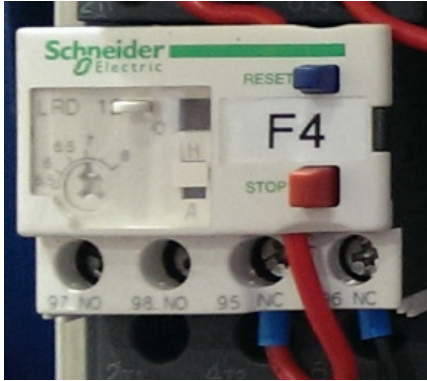

Overload contact.  
Pre-set to motor amp rate.  
**No adjustment required**

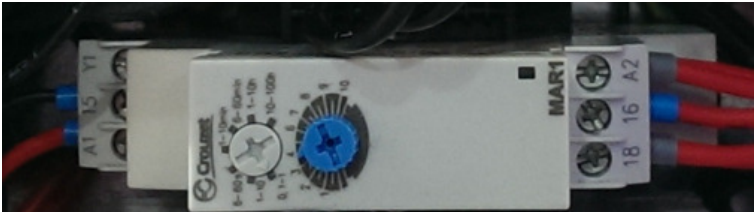

Current sensor timer.  
Pre-set.  
**No adjustment required**



Current Sensor.  
**Load Test - Onsite adjustment required.**

Increase dial clockwise from 0 up to 20 until winch design rating is achieved. (See Rating Label)

**Load cell required**

**WARNING:** Turning the dial to maximum without testing will cause damage or failure and will not be covered by warranty.

## INSTALLATION

### WIRING DIAGRAMS

The following five pages show circuit control diagrams for the AC2000 Mk4 series and the wanderlead (pendant control).

## OPERATION

### CIRCUITRY AC2000 Mk4

Motor connection 240v only is shown below:

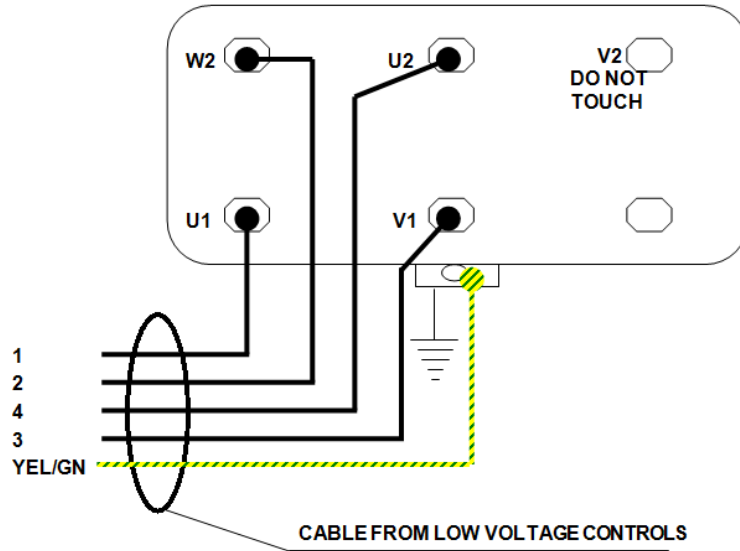

Motor connection 415v only is shown below:

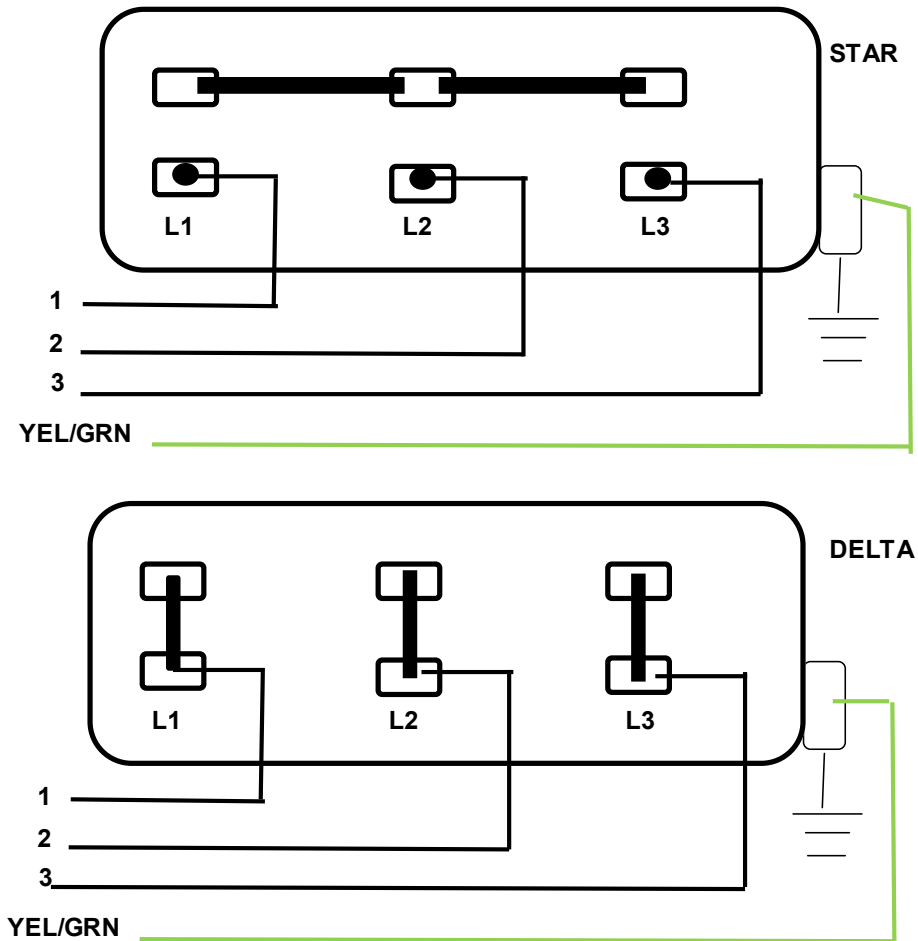

## INSTALLATION

### CONTROL CIRCUIT

#### AC2000 Mk4 – 240v 1ph and 415v 3ph Control Circuit

N.B. CONNECT AS REQUIRED FOR THREE PHASE OR SINGLE PHASE OPERATION

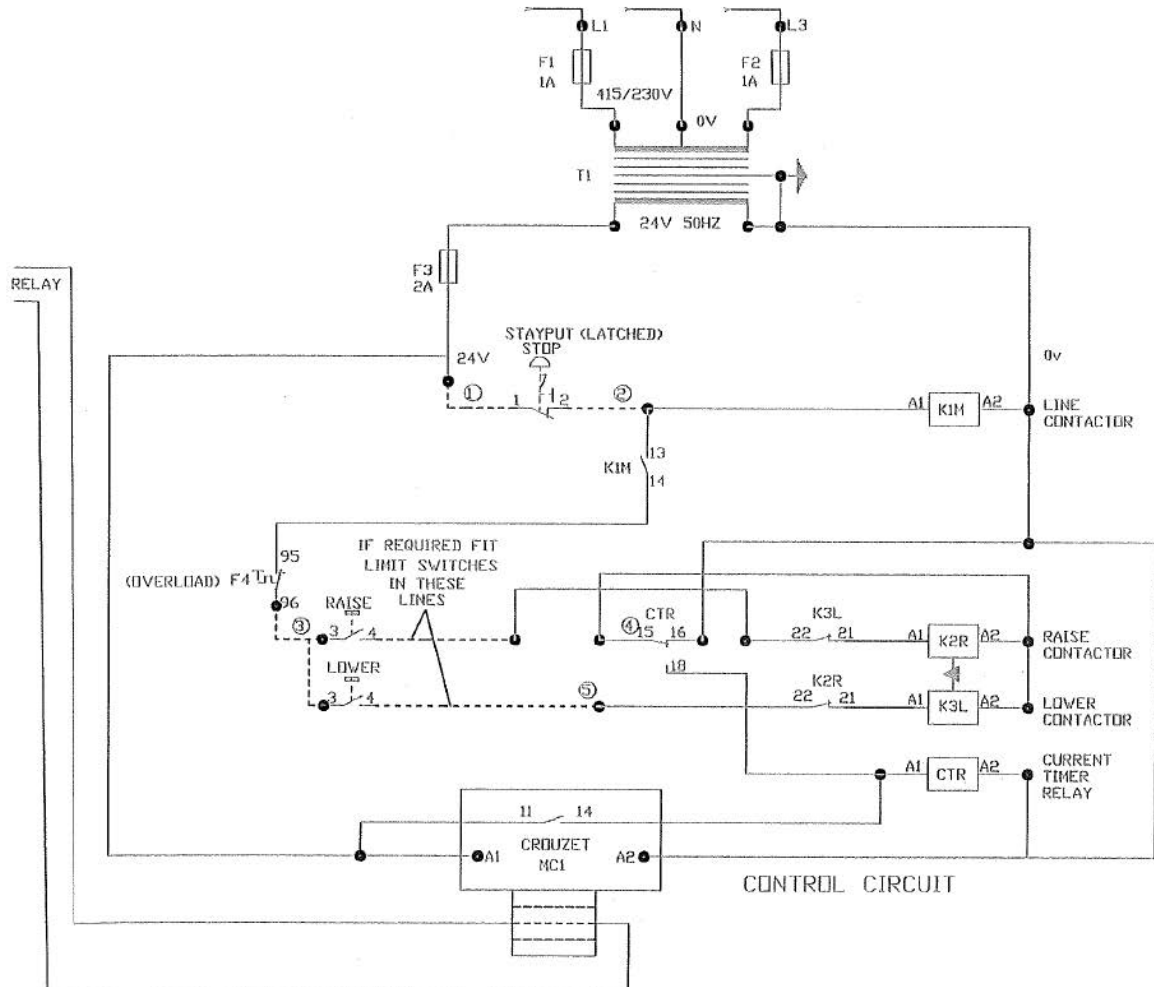

## INSTALLATION

### 240v LOW VOLTAGE CONTROL BOX

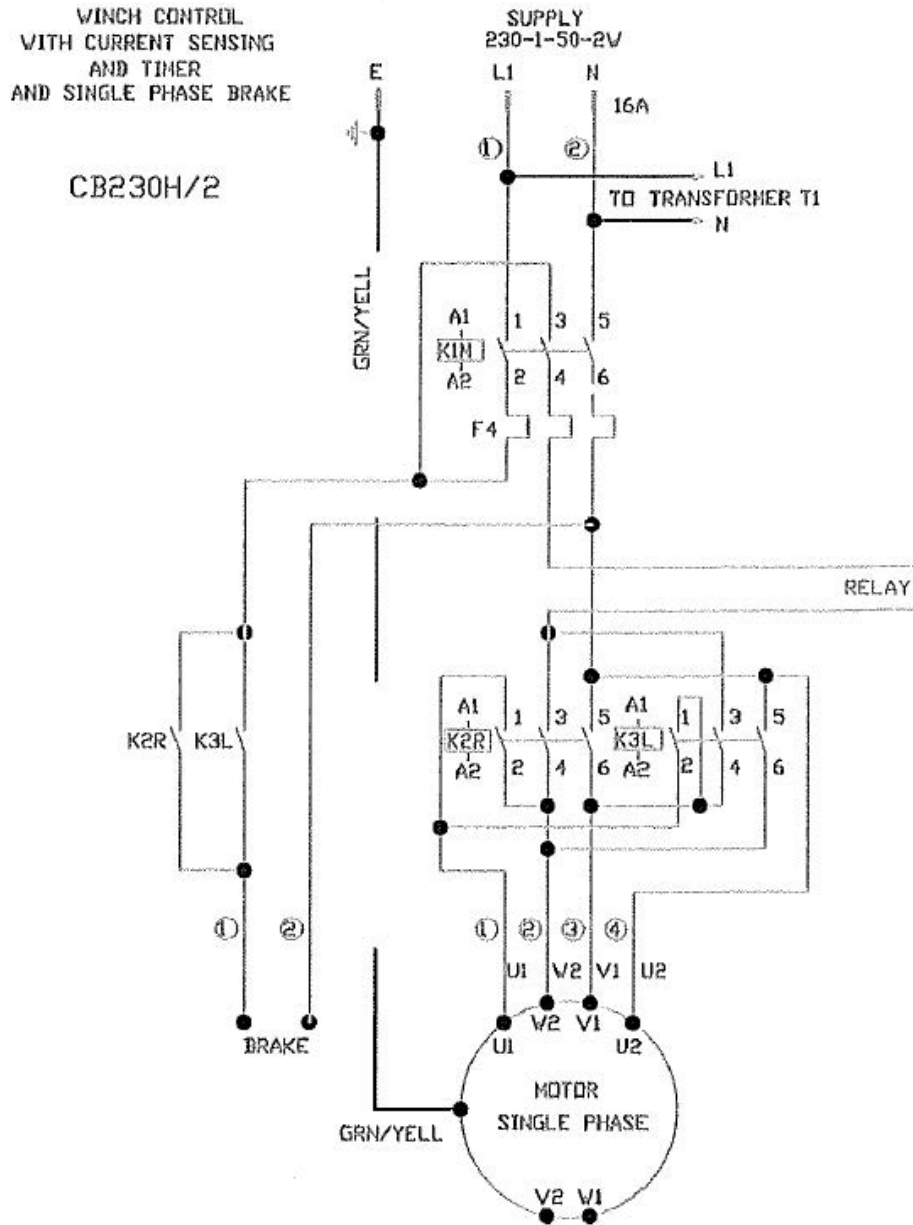

## INSTALLATION

### 415v LOW VOLTAGE CONTROL BOX

WINCH CONTROL  
 WITH CURRENT SENSING  
 WITH TIMER  
 AND 1 PHASE BRAKE

CB400HTL

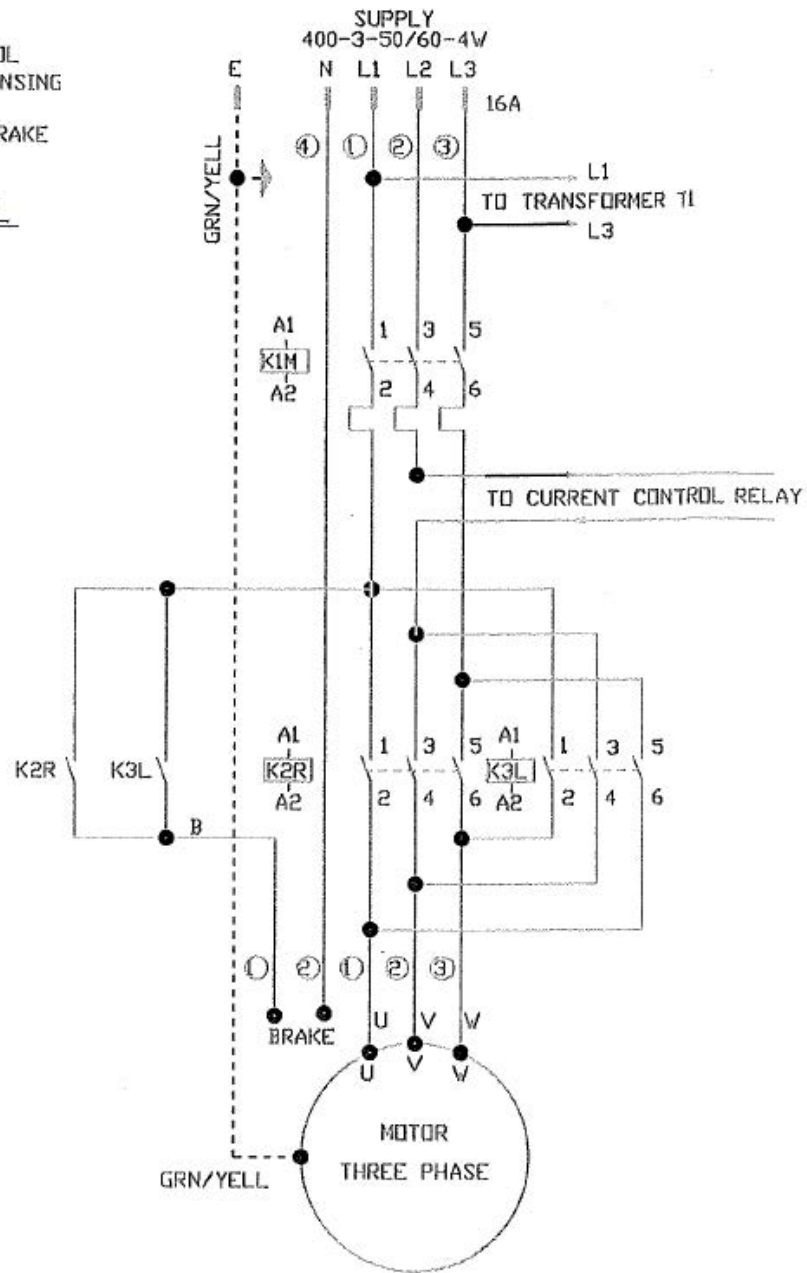

① = CONDUCTOR CORE No



## INSTALLATION

### WANDERLEADS

All AC2000 Mk4 winches are supplied with low voltage (24v) wanderlead controls.

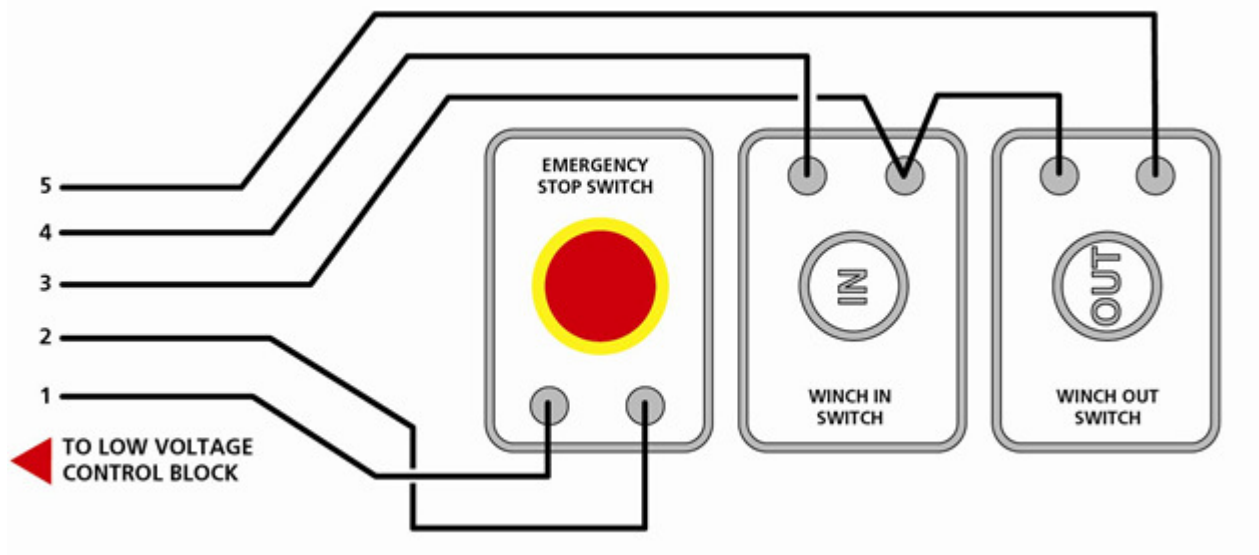

### OPERATIONAL OVERVIEW

The electric motor on the winch drives the drum via the integral planetary gearbox.

The winch is provided with a freespool clutch enabling the drum to be disengaged for paying out the wire rope. The clutch must be fully engaged for any electrical operation of the winch.

The winch has an automatic brake which will apply when the operator releases the control button and ceases either winching in or out. The automatic brake will also operate in the event of a power supply failure.

The winch is fully capable of winching in or out using the wanderlead control as the task dictates. The wanderlead also has an emergency stop button which will shut down the winch instantly. The emergency stop can be released by turning the stop button clockwise, in order to resume operation.

### WINCH ROTATION **VERY IMPORTANT**

The rotation of the drum when winching in must be correct as the load holding brake is only operational in one direction. **Viewed from the motor end, the drum rotation is clockwise when winding the rope onto the drum.**

### TESTING

After the installation is complete, a proof load test of 125% of the rated load should be carried out to ensure correct installation before the winch goes into service.

Using a load cell the winch should then be set to designed rating by adjusting the current sensor in the low voltage controls (see page 12)

## INSTALLATION

### WIRE ROPE INSTALLATION

Wear gloves and suitable protective clothing.

1. Remove Rope Drum safety guard if fitted
2. Unwind the cable by rolling it out along the ground with the tapered end nearest to the winch. NEVER wind the cable straight onto the drum from a coil.
3. Raise the cable tensioner away from the rope drum (if supplied as part of your kit), and lock in position through the corresponding holes in the tensioner frame and bracket using a suitable pin or bolt.
4. Rotate the rope drum under power until the rope fixing holes run vertically at the front of the winch.
5. Pass the rope end through the roller fairlead, UNDER the drum and back over the top of the drum to pass through the rope hole furthest way from the drum flange. Keep feeding the rope through to wrap around the drum FOUR TIMES and into the rope fixing hole nearest the drum flange.
6. Tighten the retaining screw ensuring that the rope end is flush with the exit of the hole and not protruding.
7. Feed back any excess slack to tighten the four wraps neatly on the drum.
8. Remove the locking pin from the cable tensioner to allow the rollers to rest on the rope. Note: This assembly is under tension. Special care should be taken to avoid trapping fingers, clothing etc.
9. Apply moderate tension to the rope. Take care to ensure the layers are neatly wrapped, as this will minimise damage to the lower layers of rope when a load is applied.

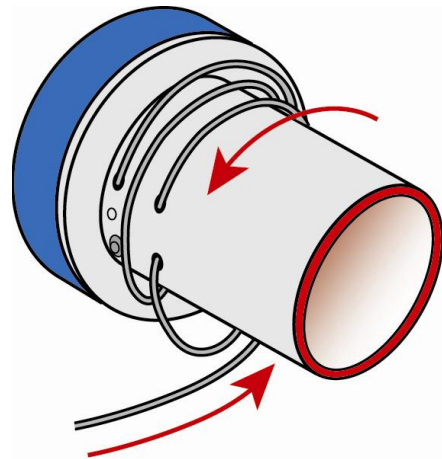
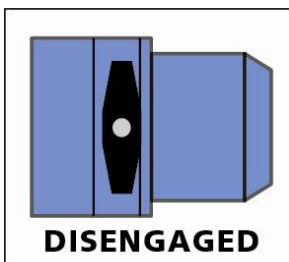

Diagram shows two wraps illustrated for clarity .



#### PULLING OUT THE ROPE

**ALWAYS WEAR GLOVES.  
DO NOT DIRECTLY HANDLE THE HOOK,  
USE THE WEBBING STRAP AT ALL TIMES.**

Dis-engage the freespool clutch by turning the handle.

Pull out the rope using the webbing strap on the hook and secure to anchor or load.

Re-engage the freespool clutch by turning the handle back to original position.

**FRESPPOOL CLUTCH MUST BE FULLY ENGAGED FOR ANY POWERED WINCHING OPERATION.**

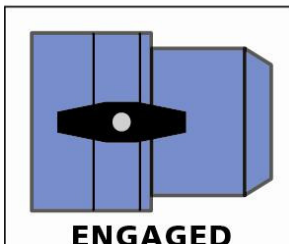

## OPERATING INSTRUCTIONS

### SAFETY PRECAUTIONS

#### **PLEASE READ THIS CAREFULLY BEFORE OPERATING THE WINCH.**

Respect for a winch and common sense in its operation, will ensure complete safety and reliability. Do not underestimate the potential danger in winching operations. Be aware of the basic dangers so you can avoid risk of accidents and unnecessary damage to the winch, the items being moved or the surrounding environment.

#### **The following safety precautions must be observed at all times whilst using the winch.**

Keep yourself and others at a safe distance to the side of the wire rope when pulling under load.

Never step over, stand near or guide a rope under tension. Always use heavy-duty gloves when handling the wire rope to protect against cuts or possible burns.

Take care of the wire rope. Check regularly for signs of damage or stretch in the form of broken strands or severe kinks along its length. If there are more than 10 strands broken in any 25mm of the rope's length then it will be significantly weakened and must therefore be replaced.

Wear and tear can be prevented by regular application of rope dressing available in aerosol form from your winch supplier. Oil and grease should never be used.

Always apply tension to the wire rope (using the safety hook webbing strap attached to the hook) to ensure that the wire rope is rewound neatly and evenly on to the drum. Loose coils or uneven wrapping are dangerous and can result in trapping or snatching when next used - and also damage to the wire rope or the winch.

Do not drive the vehicle to pull a load on the winch wire rope, e.g. as a tow rope, Any resulting shock load could break the rope or damage the winch.

If the winch is being operated at maximum capacity, drape a heavy blanket or coat over the wire rope, halfway along its length. The blanket will reduce the speed of a snapped rope.

When recovering a vehicle, the winch hook should be attached to the towing hitch, if available, or to a strap or chain around a chassis leg or cross member. **NEVER** anchor the winch hook onto bumpers, or shipping / transit anchorage.

Do not allow the load to 'snatch' during a pull, as this can momentarily double or even treble the load on the rope.

Try to position either your vehicle or the anchor point to ensure as straight a pull as possible. Use a snatch block if it is necessary to turn any corners with the rope.

When attaching the hook to the load, always double check that the hook is secure and the safety catch is fully closed. Remember that if the hook breaks away under tension, serious injury can result, as the hook will travel through the air at speed.

A minimum of five wraps of rope around the drum is recommended to hold the load.

**NEVER** hold the safety hook to rewind the winch – use the safety hook webbing strap provided.

## OPERATING INSRUCTIONS

### WINCH RATING

The winch rating on the AC2000 Mk4 series refer to maximum rated line pull, measured as the force being applied to the winch in a horizontal plane. As in the case of all winches, this refers to the first layer of rope on the drum.

<b>WINCH RATING</b> <b>BHW</b> Bushey Hall Winchmaster www.bhwgroup.com CE UK CA MODEL: VOLTAGE: XXV	SERIAL No:	00000000
	DATE OF MANUFACTURE:	00000000
	Rated to BS EN14492 WORKING LOAD LIMIT	00000000
	HOISTING:	00000000
	DRAGGING:	00000000
	ROPE DIAMETER:	00000000
	ROPE MINIMUM BREAKING FORCE:	00000000

In most cases, when the winch is being used, there is no way of accurately determining the exact pull being applied. It is important, however, to try and establish that it is within the working capacity of both the winch and wire rope and this can be done by considering the following formulae which applies for gradients up to an angle of 45°. For wheeled vehicles, the pull required to move the load equals:

$$\frac{W}{25} + \frac{(W \times \text{Angle of Gradient})}{60}$$

Where **W** = load in tonnes - and angle of gradient is in degrees.

#### EXAMPLE

If **W** is the rolling load at 4 tonne and is being pulled up a gradient of 18°, the force on the rope is:

$$\frac{4}{25} + \frac{(4 \times 18)}{60} = 0.16 + 1.2 = 1.36T$$

Remember the winch pulling capacity reduces as the number of layers of wire rope increase on the drum.

If it is necessary to work beyond the limits of either the winch or wire rope, it is essential that a snatch block be employed, which will enable the line pull to be nearly doubled. If you should have any queries regarding the maximum load applied in a particular application, please do not hesitate to contact us and we will be pleased to offer our assistance.

## OPERATING INSTRUCTIONS

### TO OPERATE WINCH

**Operators must firstly become familiar with the winch operating system with no loading applied.**

Note the position of the isolator switch in the power supply and turn it on. All systems must by law include at least one emergency stop and these should be located in an easily accessible position and this should be noted. Using the wanderlead control with the winch under no load, but with hand tension applied through the strap attached to the hook, power out and then in several times.

Now operate the freespool clutch to both see and feel the full engagement and disengagement position. With the winch disengaged freespool wire rope of the drum and then re-engage freespool.

When you are familiar with the operating features turn on the isolator. The winch can be powered both in and out using the wanderlead. The load is automatically held safely when control button is released.

The best way to become acquainted with how your winch operates is to make test runs. Plan your tests in advance. Remember that you hear your winch as well as see it operate. Come to recognise the sounds of a light steady pull, heavy pull, and sounds caused by load jerking or shifting. Gain confidence in operating your winch and its use will become second nature to you.

The uneven spooling of wire rope whilst pulling a load, is not a problem, unless there is a pile up of rope on one end of the drum. If this happens, reverse the winch to relieve the tension on the rope and move your anchor point further to the centre of the load. After the job is complete, you can unspool and rewind the wire rope neatly. Always switch off the power supply isolator switch after use and always use the webbing strap attached to the safety hook when rewinding rope back onto the drum to prevent potential injury to hands from the roller guide.

### FREE SPOOLING

To release clutch, power out winch until tension is released from cable. Lift and turn freespool lever on top of gearbox by 90°. To re-engage, turn lever back through 90° then turn the drum 1/4 turn by either hand on the drum or by pulling the rope until the freespool re-engages. Ensure that handle is fully engaged before imposing load on winch.

### LOAD TEST – CAPACITIES

AC2000 Mk4 winches are available in one rating and this refer to the safe working load, measured as the force being applied to the winch in a horizontal plane. As in the case of all winches, this refers to the first layer of rope on the drum. The winch should be tested to 125% of this capacity upon completion of installation.

## MAINTENANCE

### REGULAR MONTHLY MAINTENANCE

Externally:

The winch should be kept clean in order to prevent any build-up of corrosion on external working parts.

Inspect roller guides for grooving and if excessive, wire rope life will be reduced. Worn guides should be replaced to ensure wire rope is not damaged.

- Check winch for external damage.
- Check winch mounting for distortion and re-tighten mounting bolts if necessary.
- Operate free spool clutch mechanism to ensure correct operation, giving full engagement and disengagement.
- All external-moving parts should be lubricated with lightweight oil.
- All electrical connections and wiring should be inspected for loose connections, corrosion or fraying.
- Check the tie bars that hold the winch in alignment replace if bent or broken.
- Check the emergency STOP control to ensure it functions correctly by operating the winch and pushing the STOP button.

### SPARES

If it becomes necessary to obtain replacement parts, refer to diagram and list shown on pages 18 and 19. Please contact us quoting serial numbers if possible and model number.

BHW Group Limited reserve the right to change specifications without notice.

### CARE OF THE WIRE ROPE

It is most important that the wire rope is inspected on a regular basis, for kinks, flat spots, broken strands and other damage, and if necessary the damaged sections should be cut away and the rope reattached or completely replaced.

Check both the rope and the hook and replace under any of the following circumstances:

- 10 strands of rope or more broken with a space of 25mm (See fig.1).
- Rope shows visible signs of wasting (See fig.2).
- Deformed or excessively corroded rope.
- Twisted rope.
- Bent rope.

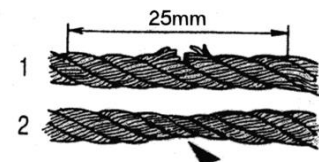

A good habit is to rewind the rope onto the winch drum after it has been used, so that it is evenly layered. To do this, rewind keeping the rope under tension. Normally the tension can be applied by hand – wear gloves.

Under no circumstances wrap the wire rope around the load being recovered and then attach the hook back on to the rope. This will result in serious rope damage or breakage. Always employ a chain or webbing strap from the hook to the load.

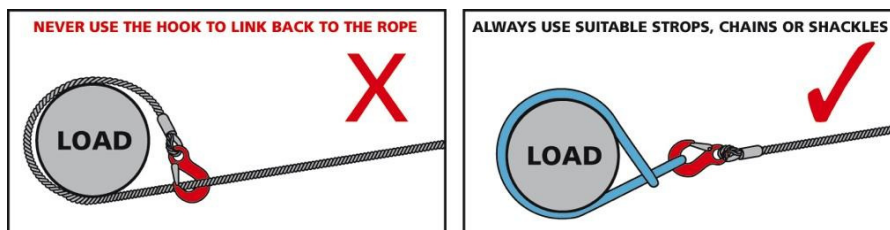

Wire rope and hook must be replaced if damaged.

If the winch is not being used on a regular basis it should be powered in and out from time to time to minimise corrosion of the internal motor components that may occur due to condensation.

Energising the motor will generate heat, which will help dissipate any moisture.

**WIRE ROPES ARE NOT COVERED BY WARRANTY.**

# PARTS DIAGRAM

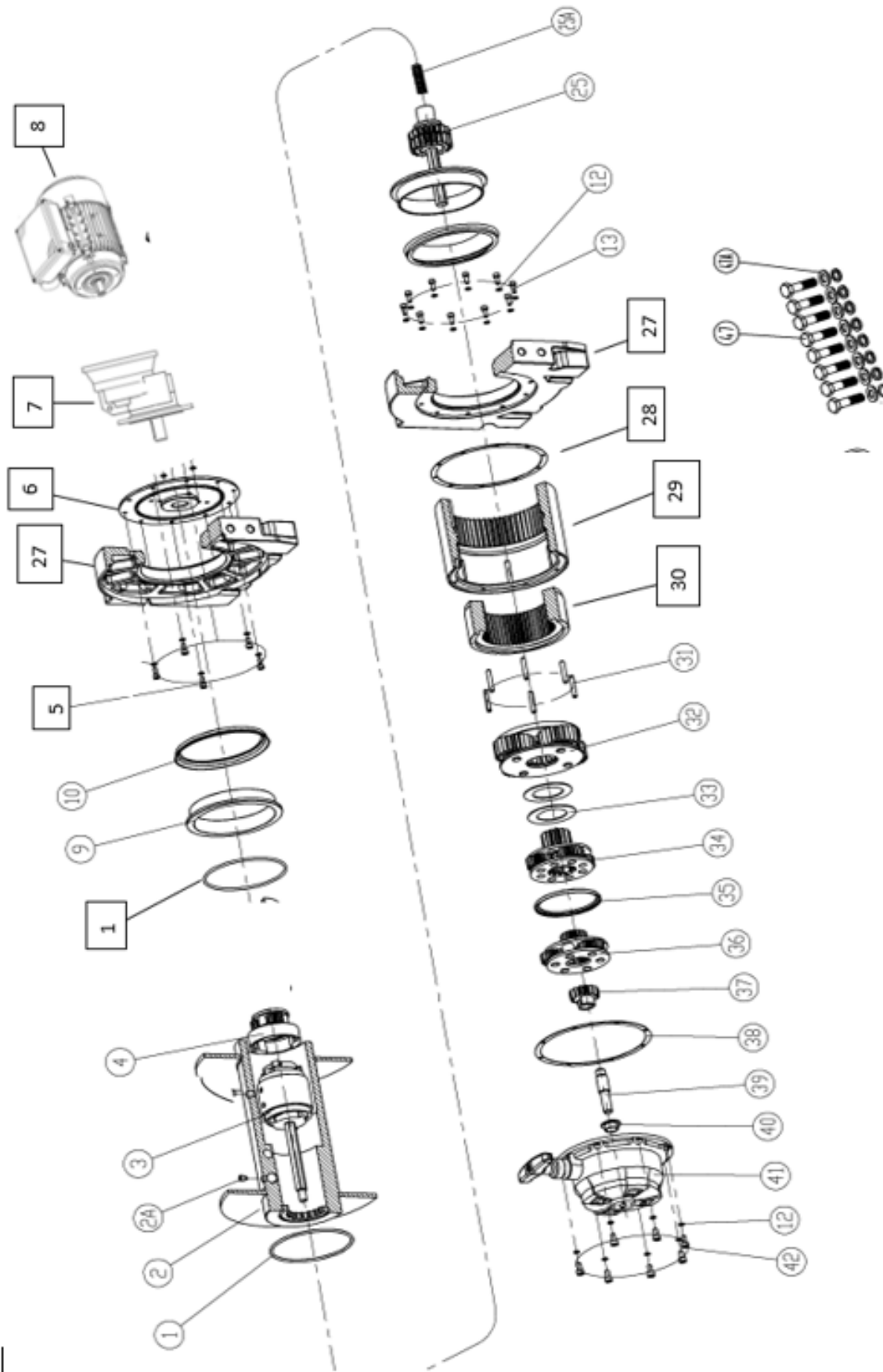

## PARTS LIST

ITEM	Part No.	DESCRIPTION	Qty
1	19632	Sealing 'O' Ring 109 x 2.65	2
2	19770	Drum Assembly	1
2A	19634	Grub Screw M8 x 10mm	1
3	20271	Drive Shaft Steel	1
4	20270	Drive Coupling Steel	1
5	2168	Bolt M6 x 25mm Cap Head H/T	10
	3374	Washer M6 Spring	
6	20269	Adaptor Plate Steel	1
	2577	Nut M12 Nylock	4
7	20139	Gearbox 3.7:1 90B5	1
	20140	Gearbox 2.1:1 100-112B5	
8	20272	Motor 240v 1.8Kw	1
	20273	Motor 415v 2.2Kw	
	9326	Motor 415v 4.0Kw	
9	19678	Anti-Dust Nylon Bearing	2
10	19679	Anti-Dust Ring	2
12	19640	Washer M5 Spring	17
13	19641	Screw M5 x 20mm	10
25	19644	4-Stage Clutch Spline Assembly	1
25A	19643	Clutch Spring	1
27	19683	Mounting Base	2
28	19645	15000 Anti-Leak Washer (10 holes)	1
29	19646	58 Tooth Long Inner Gear	1
30	19647	Clutch Gear	1
31	19648	Elastic Cylindrical Pins M6 x 35mm	6
32	19649	Gear Carrier Assembly - Output	1
33	19650	Barrier Gasket	2
34	19651	CEW12/9 Gear Carrier Assy - Intermediate 11	1
35	19652	Adjust Washer	

ITEM	Part No.	DESCRIPTION	Qty
36	19653	CEW9 Gear Carrier Assy - Intermediate 1	1
37	19654	19 Tooth Sun Gear 11	1
38	19658	170-8 Anti-Leak Ring for Gearbox	1
39	19657	4-Stage Clutch Pin	1
40	19656	Plastic Bearing	1
41	19655	Gearbox End Cover	1
42	19642	Screw M5 x 14mm	7
47	19664	Bolt M12 x 40mm H/T	8
47A	19665	Washer M12 Flat	8
	19666	Washer M12 Spring	
N/s	22101	Roller Guide	1
N/s	22102	Tension Roller	1
N/s	17894	Low Voltage Controls 240v 12-18a	1
	12990	Low Voltage Controls 415v 4-6a	
	16792	Low Voltage Controls 415v 5.5-8a	
N/s	20288	Tie Bar	1
N/s	18415	Hand Control only	1
N/s	12944	Emergency Stop Button for Hand control	1
N/s	19073	Plug 3 pin 240v	1
	19072	Plug 5 pin 415v	

Note \* N/s means not shown on parts diagram



## TROUBLE SHOOTING

<b>CONDITION</b>	<b>POSSIBLE CAUSES</b>	<b>CORRECTIONS</b>
Clutch inoperative and will not rotate	Dry gearbox and mechanism	Strip gearbox, clean and regrease
Cable Drum will not freespool	<ol style="list-style-type: none"> <li>1. Winch not mounted squarely, causing end bearings to bind drum</li> <li>2. Drum bearing is dry</li> </ol>	<ol style="list-style-type: none"> <li>1. Check mounting, refer to Winch Mounting section - Page 9</li> <li>2. Strip, clean and regrease</li> </ol>
Winch will not hold the load	<ol style="list-style-type: none"> <li>1. Excessive load</li> <li>2. Worn or damaged brake</li> </ol>	<ol style="list-style-type: none"> <li>1. Reduce the load or double the line using snatchblock</li> <li>2. Repair or replace brake</li> </ol>
Motor runs in one direction only	Broken wire or bad connections	Check for loose connections, including wanderlead control
Motor runs extremely hot	<ol style="list-style-type: none"> <li>1. Long running period at high loading</li> <li>2. Damaged motor</li> <li>3. Damaged brake</li> </ol>	<ol style="list-style-type: none"> <li>1. Cooling off periods are essential to prevent over heating</li> <li>2. Replace motor</li> <li>3. Replace brake</li> </ol>
Winch runs in reverse	Motor wire are reversed	Check wiring
Motor will not operate	<ol style="list-style-type: none"> <li>1. Isolator switch not turned on</li> <li>2. Fuse has blown</li> <li>3. Break in power lead or extension socket</li> <li>4. Inoperative motor</li> <li>5. Loose connections</li> <li>6. Emergency Stop button depressed</li> </ol>	<ol style="list-style-type: none"> <li>1. Turn on isolator switch</li> <li>2. Replace fuse</li> <li>3. Repair or replace wiring</li> <li>4. Check for voltage at armature post, replace motor</li> <li>5. Check all power lead connections are tight</li> <li>6. Check, release as necessary</li> </ol>
Motor runs but drum does not turn	<ol style="list-style-type: none"> <li>1. Clutch not engaged</li> <li>2. Drive shaft damage</li> </ol>	<ol style="list-style-type: none"> <li>1. Engage clutch</li> <li>2. Repair or replace drive shaft</li> </ol>

## WARRANTY

BHW GROUP LIMITED warrants each new winch and ancillary equipment supplied against factory defects in material and workmanship for one year from date of purchase.

The responsibility for removing the winch or ancillary equipment is the owner's together with its return, transportation prepaid to BHW Group Limited.

BHW Group Limited will, under this warranty, without charge repair or replace at its option, parts, which on inspection are deemed to be defective. The loss of use of the produce, loss of time, inconvenience, commercial loss or consequential damages are not covered.

Warranty does not apply where the product has been tampered with or altered in any way, or where the serial number or date stamp has been defaced, altered or removed, or if in the view of BHW Group Limited the damage or failure occurred from misuse, negligence or accident.

### **THIS WARRANTY EXCLUDES THE WIRE ROPE**

BHW Group Limited reserve the right to change the design of any product without assuming any obligation to modify any product previously supplied.

Winches or equipment returned under warranty should be despatched to BHW Group Limited service department at the address shown below, with full name and address of sender, a statement detailing the defect and proof of purchase.

**BHW**  
**Bushey Hall Winchmaster**  
**www.bhwgroup.com**

Service Department  
Bushey Hall Winchmaster  
6 South Orbital Trading Park  
Hedon Road, Hull HU9 1NJ

Telephone: +44 (0)1482 223 663  
Email: [sales@bhwgroup.com](mailto:sales@bhwgroup.com)  
Website: [www.bhwgroup.com](http://www.bhwgroup.com)

**AC2000 Mk4 VOLTAGE & RATING.....**

**SERIAL NUMBER.....**

**DATE OF PURCHASE.....**