

BHW

Bushey Hall Winchmaster

www.bhwgroup.com

PULLMASTER PL5D Freefall Hydraulic Winch

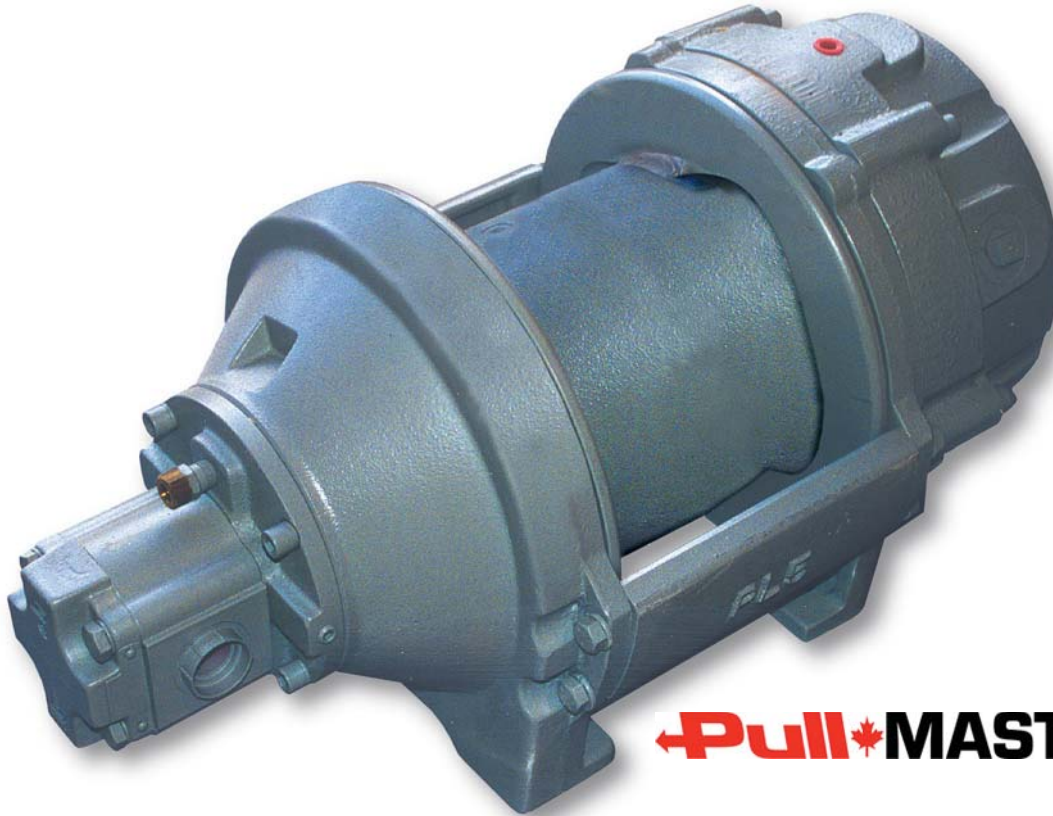

PULLMASTER®

Unique Mini-Piling Freefall Planetary Hydraulic Winch

FEATURES INCLUDE

- *500kg and 1000kg hammer weight lifting capacities available*
- *Long service life*
- *Compact design – totally enclosed*
- *Can be used for raising and lowering a load when FREEFALL is not activated*
- *Automatic multi – disc brake*
- *High speed operation*
- *Built to operate in marine environment*

Bushey Hall Winchmaster sales@bhwgroup.com www.bhwgroup.com

Southern Office: Lismirrane Industrial Park, Elstree Road, Elstree, Herts, WD6 3EE Tel: +44 (0)20 8953 6050

Northern Office: 6 South Orbital Trading Park, Hedon Road, Hull, East Yorkshire, HU9 1NJ Tel: +44 (0)1482 223 663

Bushey Hall Winchmaster is a division of BHW Group Limited. Registered in England No. 1342461 VAT No. 301 7915 80



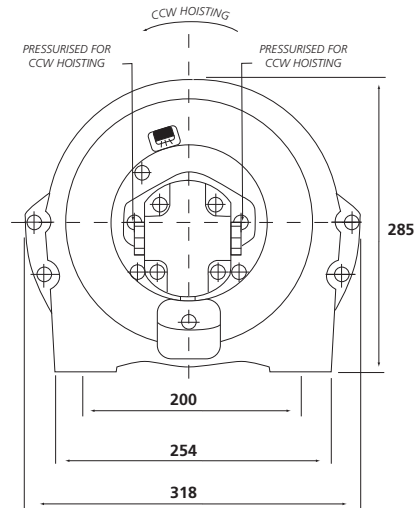
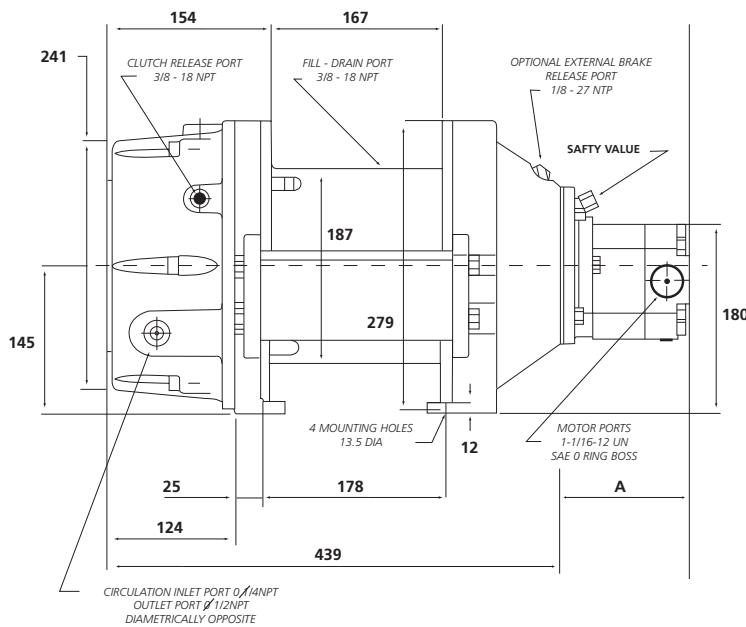

ROTATION COUNTERCLOCKWISE WHEN LIFTING
(VIEWED FROM MOTOR END)

PERFORMANCE

MODEL NUMBER	HYDRAULIC REQUIREMENTS		DRUM		BARE DRUM		MEAN DRUM		FULL DRUM	
	FLOW Lt/min	PRESSURE Bar	TORQUE Nm	R.P.M.	LIFTING CAPACITY Kg	LINE SPEED m/min	LIFTING CAPACITY Kg	LINE SPEED m/min	LIFTING CAPACITY Kg	LINE SPEED m/min
PL5 -12-211-ID	42	155	1765	35	1815	22	1580	26	1340	30
PL5 -12-213-ID	42	155	883	69	910	43	790	51	670	58
PL5 -12-210-ID	91	145	1986	66	2000	41	1775	48	1500	56

DIMENSIONS

MODEL NUMBER	A	
PL5 -12-211-ID	135	Alu: 83mm
PL5 -12-213-ID	116	Alu: 63.5mm
PL5 -12-210-ID	145	Alu: 92.5mm

CABLE STORAGE m

DRUM DIA	FLANGE DIA	DRUM LENGTH	WIRE ROPE DIA mm			
			6	8	10	12
187	279	167	106	66	40	30

MAXIMUM RECOMMENDED HAMMER WEIGHT

- PL5 -12-211-ID -1000Kg
- PL5 -12-213-ID -500Kg
- PL5 -12-210-ID -1100Kg

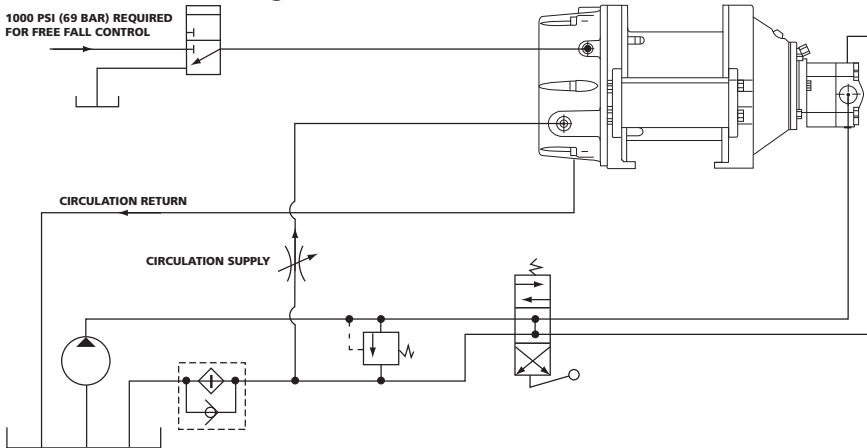

NOTES

These winches must not be used for the movement of personnel and 5 wraps of wire rope must be maintained on the drum.

Data shown is approximate and intended as a guide only.

NORMAL OPERATION

The winch is set to permanent lift mode. When the hammer reaches required height above pile it is released using manual or electric control valve. Maximum operating pressure 155 Bar. Free fall clutch release 52 Bar.

TYPICAL HYDRAULIC CIRCUIT SHOWING HYDRAULIC FLOW

- 42 Lt/min to winch motor (max.)
- PL5 -12-211-ID & PL5 -12-213-ID
91 Lt/min to winch motor (max.)
- PL5 -12-210-ID
 - 8 Lt/min cooling oil to free fall clutch
 - 2.0 Lt/min to release clutch
- Total weight (Wire rope not included) 100kg

WARRANTY

Each new winch is guaranteed against defects in workmanship and material defects for a period of twelve months from date of purchase.

Wire ropes are not included under warranty.