



## BH DELTA S2300 or S3300 WINCH KITS

### BH DELTA S2300 kit includes

Electric winch, solenoid kit, aluminium hawser fairlead, 4.5m heavy duty 2 button wanderlead, mounting plate and 9mm x 23m UHMPE (Ultra High Modulus Polyethylene) high tensile Marlow Winchline Dynaline® rope with safety latch hook.

### BH DELTA S3300 kit includes

As S2300 kit but comes with 9mm x 23m UHMPE high tensile pre-stretched Marlow Dynaline Max® rope with safety latch hook.

Total approximate kit weight: 40kg

## MARLOW ROPES SUPPLIED BY BHW GROUP

Features of Marlow Dynaline® and Dynaline Max® ropes:

- 8 times lighter than wire ropes
- 70% stronger than comparable wire ropes
- Will not kink
- No wire splinters
- No strength loss when overlapped on winch drum
- Ropes will float
- Virtually no recoil in unlikely event of rope failure

## ADDITIONAL EQUIPMENT & SERVICES

- Alternative roller guide in place of hawser fairlead
- Electric isolator switch
- Auxiliary industrial 16 amp plug and socket kit for wanderlead connection
- Fuse and fuse holder • Snatch block • Radio Control
- Full or partial fitting can be provided, including load testing and certification

## BH DELTA S2300 & S3300 12v or 24v DC Electric Recovery Winches Prepared for use with high tensile synthetic ropes 2300kg or 3300kg Line Pull

**Light GVW Car Transporters, Fire & Rescue,  
Utility Vehicles, Spec-Lifts, 4x4's**

*Low profile planetary winches incorporating a large electric motor, ensuring good service life.*

## FEATURES INCLUDE

- **2300kg (22.6kN) or 3300kg (32.4kN) line pull**
- **Supplied with Marlow Winchline Dynaline® or Dynaline Max® synthetic ropes**
- **EN14492-1 compliant**
- **Powerful series wound, high torque motor options**  
12v or 24v
- **Optional electronic load limiting device**  
Pre wired to solenoid, switches off winch at rated line pull
- **Automatic braking action in drum**
- **Aluminium hawser fairlead**  
Minimum protrusion, a major benefit on lightweight transporters with short bed lengths or 4x4 vehicles.
- **Rope positively secured to drum**  
Positively secured to drum with a rope end stock engaged into a slot on the drum.

## NOTES ON HIGH TENSILE SYNTHETIC ROPES

High tensile UHMPE Synthetic Ropes are popular for a wide range of vehicle winching applications where the user prefers handling these soft pliable ropes.

They are very light to manoeuvre and the overall weight saving can be very important in applications such as 4x4's and on light GVW car transporters.

The ropes used on the BH Delta 'S' winches have a tensile strength in excess of the strength of comparable wire ropes. The winch rating is calculated on a 3:1 factor of safety at the maximum winch pulling capacity (compared to requirements for a wire rope of only 2:1).

In the right applications the BH Delta 'S' series winches with a Marlow Dynaline® or Dynaline Max® rope make a great combination.

Please note: In applications where ropes are regularly subjected to sharp edges or excessive abrasion, use of UHMPE Synthetic ropes is not advised.

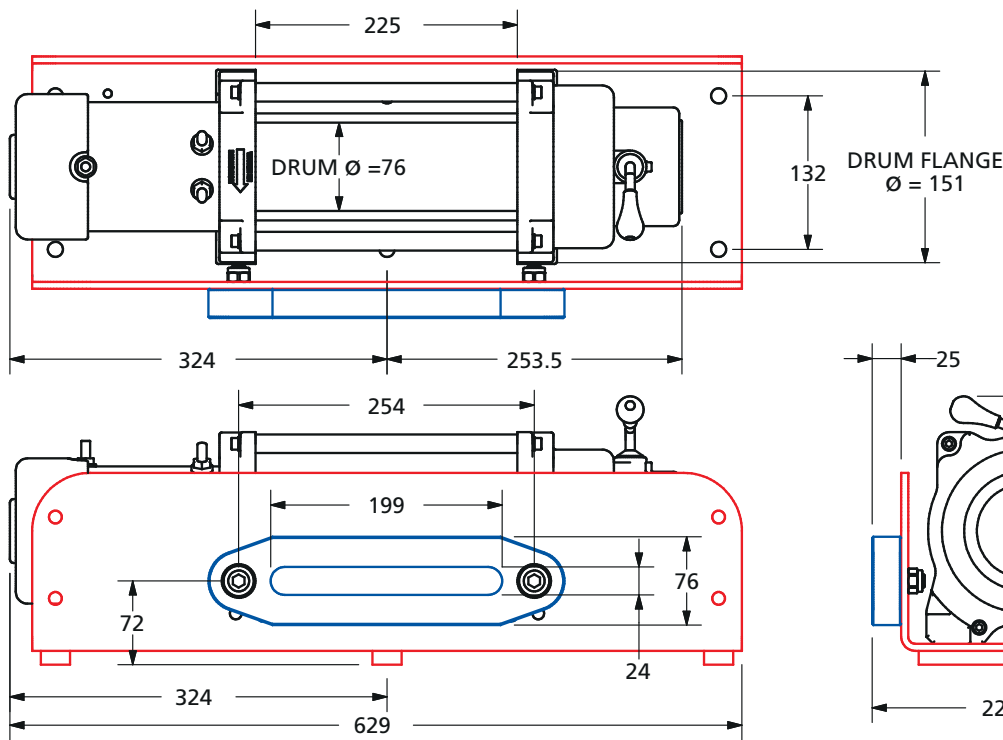

Can also be supplied with Emergency Stop, Safety Solenoid and In-Cab Switch (not shown).

Roller guides also available on request.

		LAYER		
		1	2	3
Maximum Rated Line Pull by Layer*	S2300	kgf 2300	1910	1634
	S3300	kgf 3300	2740	2344
Cable Drum Capacity Cumulative by Layer	S2300 & S3300	kN 22.6	18.7	16
		kN 32.4	26.9	23
		m	7	15
			23	

By incorporating a snatch block in the line it is possible to double these capacities.

PERFORMANCE FIRST LAYER OF CABLE				
LINE PULL	LINE SPEED (approx)		AMP DRAW (approx)	
kgf	12v m/min	24v m/min	12v	24v
3000	2	2.1	320	160
3300	1.5	1.6	360	180

All figures are based on battery maintaining normal voltage.

## SPECIFICATIONS

Rated Line Pull (single line)	Maximum recommended working capacity 2300kg (S2300) and 3300kg (S3300) to comply with EN14492-1. Stall capacity 4300kg without load limiter installed and calibrated. Note: A fast action load limiter must be fitted. If a BHW load limiter is not specified, an alternative load limiter must be provided for EN14492-1 compliance.
Gear Ratio	216:1 for either 12v or 24v.
Motor	High torque series wound 12v (6hp) or 24v (4.7hp).
Switching	Heavy duty, double acting solenoids can be mounted adjacent to winch or on to the winch tie bars with straps provided.
Wanderlead Control	Commercial heavy duty type with 2 operating buttons and 4.5m cable. Other lengths and additional emergency stop button versions available on request.
Aluminium Hawser Fairlead	Supplied as standard. Alternatively, a roller guide can be provided.
Synthetic Ropes (High Tensile UHMPE)	S2300: 9mm x 23m Marlow Winchline Dynaline®. Minimum breaking strain 68.83kN (7020kkg) S3300: 9mm x 23m Marlow Winchline Dynaline Max®. Minimum breaking strain 98.45kN (10,035kg)
Freespooling	Lever on gear housing to disengage clutch.
Approximate Weights	Winch with mounting plate, aluminium hawser fairlead and soft rope: 35kg Solenoid pack, connecting wiring and 4.5m wanderlead: 5kg
Load Limiting Device (Option)	Pre-wired and fitted to underside of solenoid pack. Can be calibrated to shut down winch when maximum load limit is reached.

## NOTES

These winches must not be used for the movement of personnel and 5 wraps of rope must be maintained on the drum.

Data shown is approximate and intended as a guide only.

DURLFLDLGDURDLDDUULUGUDGDUNRDUR5RLLG8.

## WARRANTY

Each new winch is guaranteed against defects in workmanship and material defects for a period of twelve months from date of purchase.

Ropes are not included under warranty.