



Unloading or reloading with **CARPET•TUG™ 500** is made easy, simply by attaching the wire rope to a webbing harness looped around the end of the carpet roll.



The new powerful DC winch, fed through the patented rotator system, gives added capacity to the **CARPET•TUG™ 500**, handling up to 500kg carpets with ease.

PROVEN, RELIABLE SYSTEMS FROM BHW WITH MORE THAN 12 YEARS INDUSTRY EXPERIENCE



Back problems account for a high percentage of working days lost to industry, particularly in the carpet business.

CARPET•TUG™ 500 reduces the risk of injury and enables a single operator to deliver heavier carpets and flooring efficiently.

EUROPEAN PATENT NO. 98 303456.2 ™ CARPET•TUG IS A REGISTERED TRADEMARK OF THE BHW GROUP LIMITED.

CARPET•TUG™ 500 Unique 500kg Winching System

FEATURES INCLUDE

- Supplied as a complete ready to fit kit - easy to install with a simple 8 bolt fixing
- Total weight of **CARPET•TUG™ 500** is only 168kg
- **CARPET•TUG™ 500** applies a force up to 500kg and is load limited for safety
- Reduces risk of back injury or loss of man hours
- Compact size : 260mm high x 460mm deep - adjustable 2340mm to 2515mm length (as standard)
- Fully load tested and compliant with the EN 14492 / 1 & 2 Machinery Directive
- CE marked and issued with a Declaration of Conformity



A MAJOR AID TO ENSURE COMPLIANCE WITH EU MANUAL HANDLING REGULATIONS

Heavier rolls of flooring have become available making them even more difficult to man handle during delivery. The new **CARPET•TUG™** helps the operator, safely.

New EU regulations regarding machinery and its safe use have also been recently introduced, emphasising the requirement to provide manual handling aids for staff involved with the delivery process. **CARPET•TUG™** is the answer...

ADJUSTABLE TO FIT VEHICLE BODY WIDTHS

Constructed with an adjustable width, low profile steel beam, the **CARPET•TUG™ 500** is easily secured to the vehicle with just 8 bolts (supplied).

Powder coated and robust enough to resist impact damage, the beam also houses the winch and the patented wire rope delivery system, including a central rotator to enable operation in virtually any direction.

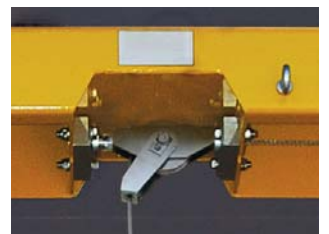

OPTIONAL EXTRA

FM•CONNECT REMOTE CONTROL SYSTEM – CONTACT SALES FOR DETAILS.

Bushey Hall Winchmaster sales@bhwgroup.co.uk www.bhwgroup.com

Southern Office: Lismirrane Industrial Park, Elstree Road, Elstree, Herts, WD6 3EE Tel: +44 (0)20 8953 6050 Fax: +44 (0)20 8207 5308

Northern Office: 6 South Orbital Trading Park, Hedon Road, Hull, East Yorkshire, HU9 1NJ Tel: +44 (0)1482 223 663 Fax: +44 (0)1482 218 285

Bushey Hall Winchmaster is a division of BHW Group Limited. Registered in England No. 1342461



CERT. No. 1769

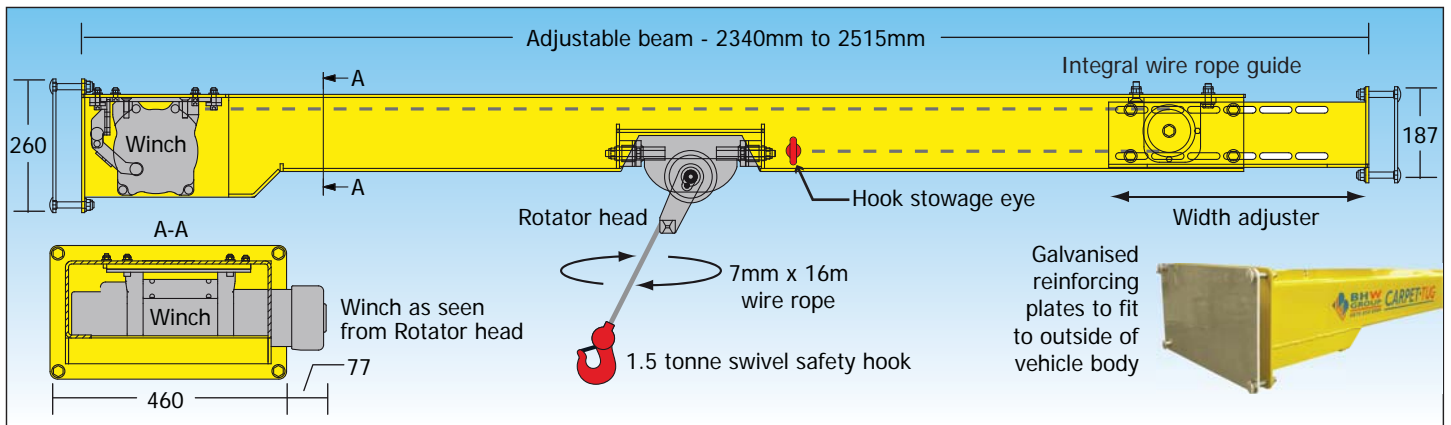

All moving parts run on maintenance free nylon bushes for cleanliness and prolonged life. Beam is powder coated steel.

EASY TO INSTALL...

This quick-to-fit system is supplied as a complete kit and secured into the vehicle body with just 8 bolts (supplied).

The slim beam is adjustable in length to suit vehicle body width - and robust enough to resist impact damage.

The beam also houses the electrics, including an isolator switch.

Power cables are routed from the vehicle's battery and secured into the heavy duty connector provided.

The system is operated using a heavy duty 4.5m wanderlead which has a heavy duty plug. The auxiliary socket for this can be positioned either on the Carpet Tug or elsewhere as required.

An Emergency Stop button is also provided that activates a third solenoid to cut the power supply to the winch motor.



SUPPLIED AS A FULL KIT - READY TO INSTALL

- Powder coated, adjustable steel beam with fitted central rotator, wire rope guides, fitting plates and bolts
- Ready to fit wiring looms and control boxes
- Fitted heavy duty DC electric winch 12v or 24v
- 7mm x 16m wire rope (tested and certificated)
- CE certificated polyester 'round sling' webbing strap
- 4.5m wanderlead and auxiliary socket
- Emergency stop button, isolator switch and fuse
- Heavy duty connectors
- **CARPET•TUG™ 500** operator's manual
- 12 months full warranty (excluding wire rope)

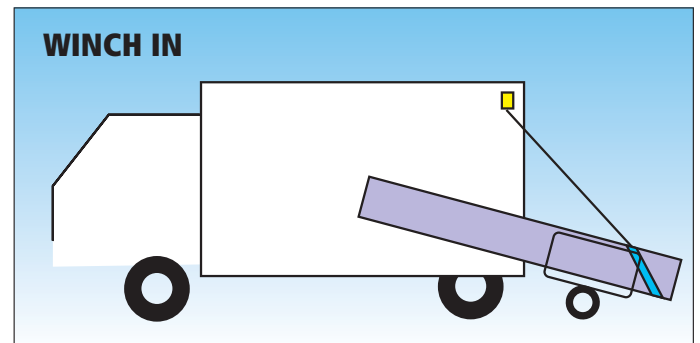
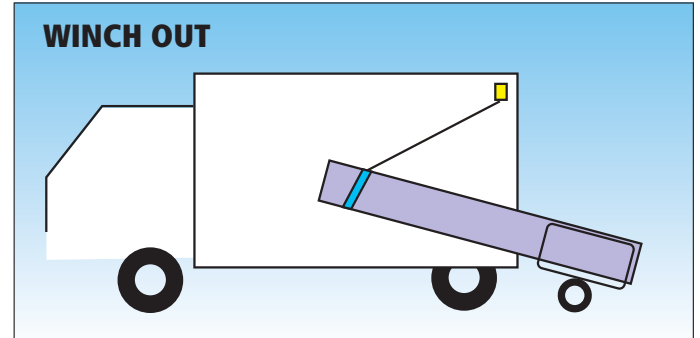

NOW EVEN MORE POWERFUL & FASTER

The new **CARPET•TUG™ 500** includes a more powerful, DC electric winch to enable handling of even heavier carpets.

CARPET•TUG™ 500 also provides a faster line speed to reduce unloading time.

Limited to 500kg of force for safety purposes, the winch is working well within its capacity, ensuring a long life with a minimum of maintenance.

The patented system ensures neat wrapping on to the winch drum, avoiding tangling or damage to the wire rope.

The wire rope is totally visible throughout the unloading or reloading process, which is proven to be a major aid to easy operation.



Bushey Hall Winchmaster sales@bhwgroup.co.uk www.bhwgroup.com

Southern Office: Lismirrane Industrial Park, Elstree Road, Elstree, Herts, WD6 3EE Tel: +44 (0)20 8953 6050 Fax: +44 (0)20 8207 5308

Northern Office: 6 South Orbital Trading Park, Hedon Road, Hull, East Yorkshire, HU9 1NJ Tel: +44 (0)1482 223 663 Fax: +44 (0)1482 218 285

Bushey Hall Winchmaster is a division of BHW Group Limited. Registered in England No. 1342461



CERT. No. 1769