

FITTING & OPERATING INSTRUCTIONS



CHANDELIER WINCH

**CH100 (100kg), CH200 (200kg), CH300 (300kg), CH600 (600kg)
240v x 1ph**

Part Nos. CH100 – 10961, CH200 – 3392, CH300 – 3393, CH600 - 12539

**CONFORMING TO
EN14492 Cranes – Power Driven Winches and Hoists – Part 2: Power Driven Hoists**

CONTENTS

INTRODUCTION	3
NEW EUROPEAN STANDARDS & BHW GROUP LIMITED	3
INSTALLER RESPONSIBILITY FOR CE COMPLIANCE	3
HOIST INFORMATION	
HOIST SPECIFICATIONS	4
HOIST DIMENSIONS	5-6
HOIST PERFORMANCES	7
HOIST LABELS	7
ADDITIONAL EQUIPMENT	
DETAILS ON ADDITIONAL EQUIPMENT	8-9
INSTALLATION	
GENERAL INSTALLATION NOTES	10
TYPICAL HOIST INSTALLATION	10
ELECTRICAL INSTALLATION	11
WIRING DIAGRAMS STANDARD 240v	12
WIRING DIAGRAMS 240v CH600	13-14
WIRING DIAGRAM LOW VOLTAGE	15
WINCH ROTATION	16
WIRE ROPE INSTALLATION	16
LOAD TESTING	16
ATTACHING THE LOAD	16
LIMIT SWITCHES TO CONTROL UPPER AND LOWER LIMITS	17
MAINTENANCE	
MONTHLY MAINTENANCE	18
CARE OF THE WIRE ROPE	18
REGULAR MAINTENANCE & SERVICING	19
WINCH PARTS	
PARTS DIAGRAM & PARTS LISTS	20-23
WARRANTY	24

INTRODUCTION

Thank you for purchasing a chandelier winch from Bushey Hall Winchmaster, one of a range of professional winches and hoists available from the BHW Group Limited.

These winches are not designed for the movement of personnel.

PLEASE READ THIS MANUAL CAREFULLY BEFORE INSTALLATION OR OPERATION OF THE WINCH

Those responsible for the installation and the operation of the winch must read and understand this manual.

This introduction also includes information on the European standard EN14492-2 for hoists and the importance of correct product specification, installation and testing to ensure the essential Health and Safety requirements of the EC machinery directive are met.

EUROPEAN STANDARDS & BHW GROUP LIMITED

The harmonised European standard: EN14492-2 for power driven hoists provide the means for conformity to essential Health and Safety requirements of the EN Machinery Directive. This standard is law throughout the European Union and must be applied. Conformity to these standards is the joint responsibility of the hoist supplier, the installer and the operative of the machine.

Selecting the correct hoist for the application is very important not only from the health and safety aspect, but also to maximise product life and value for money by reducing maintenance costs and any possible down time.

BHW Group Limited products are fully compliant and carry a CE mark. A Declaration of Conformity is also supplied with each product. BHW Group Limited aim to ensure the correct machine is supplied to suit the application and we welcome the opportunity of further discussing the proposed application and offer advice. It will help us considerably if information regarding the maximum and average loads to be lifted or pulled - and approximate frequency of use can be provided should more assistance be required.

INSTALLER RESPONSIBILITY FOR CE COMPLIANCE

1. Mount winch in accordance with instructions.
2. Install a suitable wire rope according to the specifications of the selected winch (See specifications, page 4).

Maximum rope lengths are dictated by the hoist specifications. This is the maximum rope length permissible to ensure compliance with EN14492-2 as this requires a 1.5 x wire rope diameter allowance from the top layer to the drum flange.

3. Attach wire rope to the drum as per WIRE ROPE INSTALLATION INSTRUCTIONS. (Page 13).
4. Load test the winch following installation to check the integrity of the mounting using a weighted object prior to fixing the proposed load. The load test should be rated to at least 125% of the proposed load to be lifted. See Page 13.
5. The wire rope should be attached to the load with a suitable connector such as an industrially rated and CE marked high tensile bow shackle. All connectors should be rated for lifting at a safety factor of 4:1. Example: A 500kg (0.5 tonne) connector has a maximum yield of $0.5 \times 4 = 2$ Tonne.
6. The installation must be fully tested and certified by a qualified electrical engineer.

WINCH INFORMATION

WINCH SPECIFICATIONS

Models	CH100 (100kg), CH200 (200kg), CH300 (300kg), CH600 (600kg) EN 14492-2 Compliant
Construction	Die cast aluminium end housings with cast alloy drum
Drum Rotation	CH100, CH200, CH300 & CH600 Anti-clockwise viewed from motor end when pulling in

The following chart refers to the four variants of BHW Chandelier winches. Larger capacity winches are also available for heavier applications. Data shown is approximate and intended as a guide only.

		CH100	CH200	CH300	CH600
Lifting Capacity	3 rd Layer	100kg	200kg	300kg	600kg
Voltage:		240 volt x 1 phase			
Motor Type:		Induction motor			
Outputs	Kilowatts:	0.18kw	0.37kw	0.37kw	0.55kw
	Amperes:	1.6amp	3.6amp	3.6amp	4amp
Braking:		Dual mechanical and electromagnetic motor brake			
Duty Cycle:		All Chandelier winches have a duty cycle of 25%, with a maximum of 60 starts per hour			
Weight – Winch only		9kg	20kg	25kg	30kg
Drum	Diameter:	70mm	95mm	95mm	102mm
	Length:	46mm	97mm	147mm	220mm
	Flange Ø:	158mm	190mm	190mm	180mm
Wire rope	Diameter:	4mm	5mm	5mm	7mm
	Construction:	19 x 7 spin resistant rope, 1960N ² grade tensile			
Rope to mean drum ratio:		18:1	20:1	20:1	15:1
Minimum recommended distance of winch to first diversion point		550mm	1165mm	1765mm	2640mm

NOTES:

- Weights shown are for the winch only. The weight of the whole kit being used should be assessed prior to installation, and suitable reinforcement made to the ceiling joists should be made as necessary. If in doubt, consult a builder or structural engineer.
- It is important that the wire rope used is in accordance the specifications given and is also spin resistant to prevent unwanted rotation of the load when being raised or lowered.
- The recommended distance from the winch to the first pulley in a straight line is necessary to optimise even wrapping of the wire rope on to the drum. A shorter distance may result in the wire rope becoming tangled on the drum and reduce efficiency of the winch.

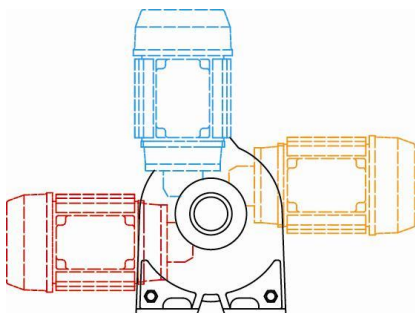

ROTATIONAL MOTOR OPTIONS

The CH200, CH300 & CH600 motors can be mounted in any of three positions on the winch to suit space available.

HOIST INFORMATION

HOIST DIMENSIONS

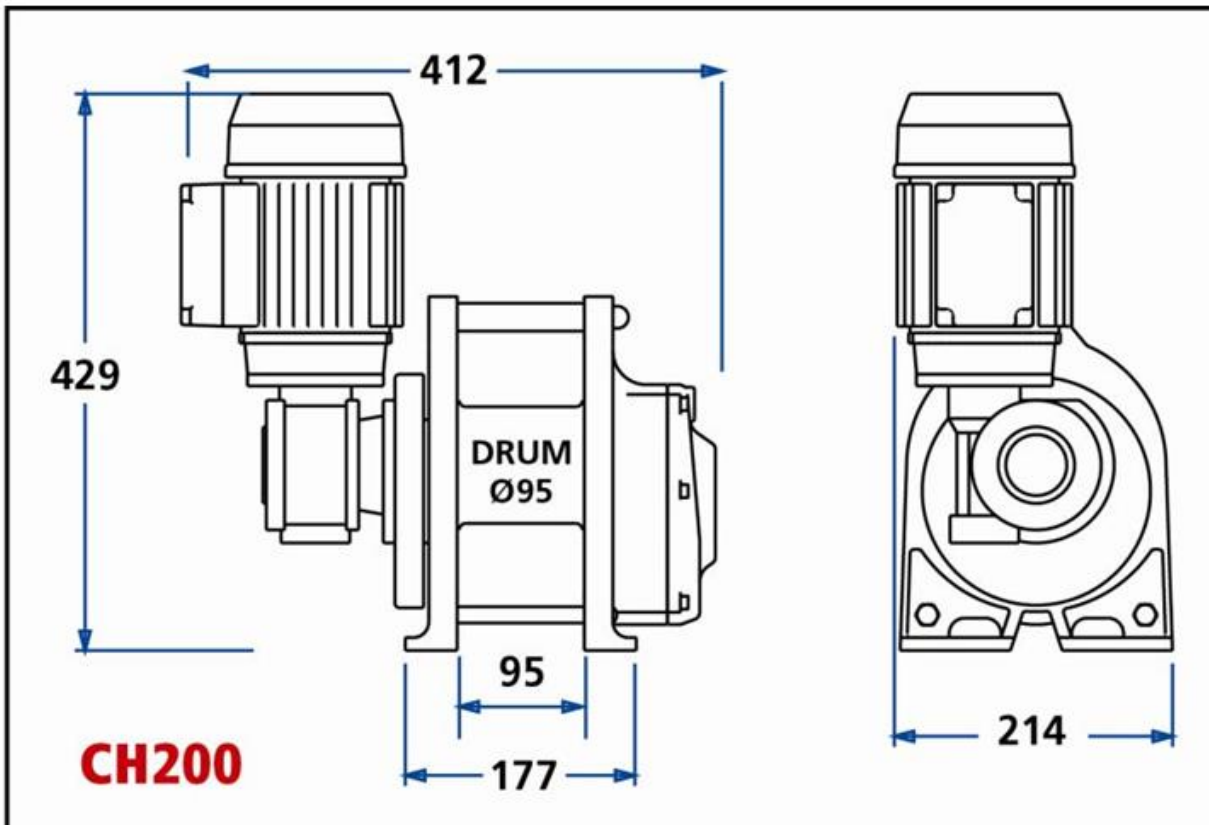
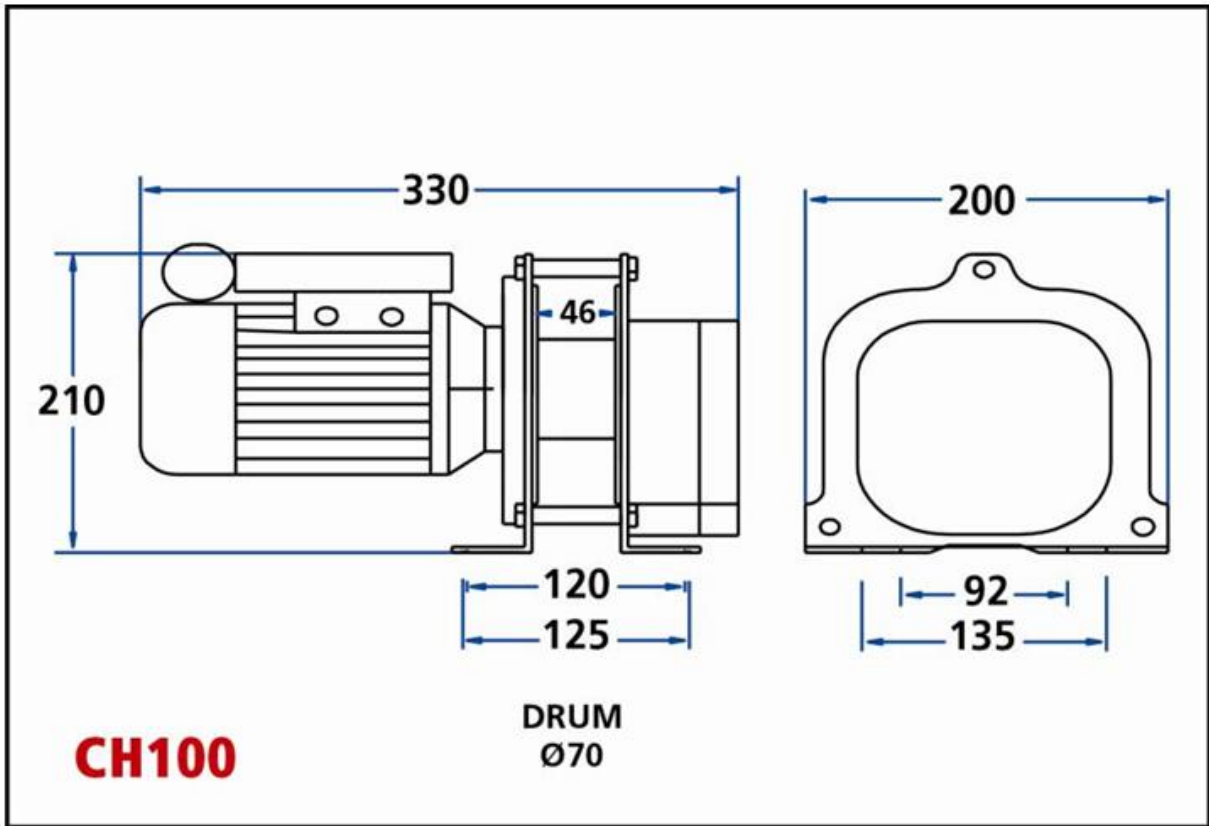

HOIST INFORMATION

HOIST DIMENSIONS

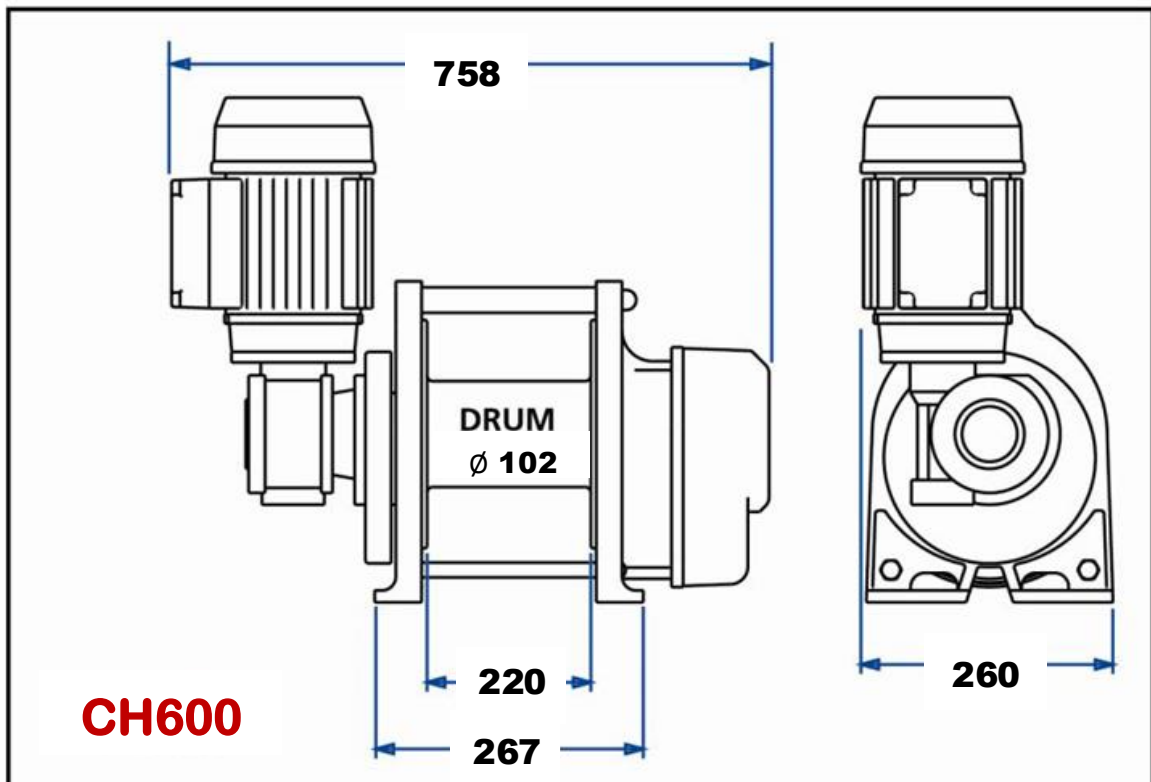
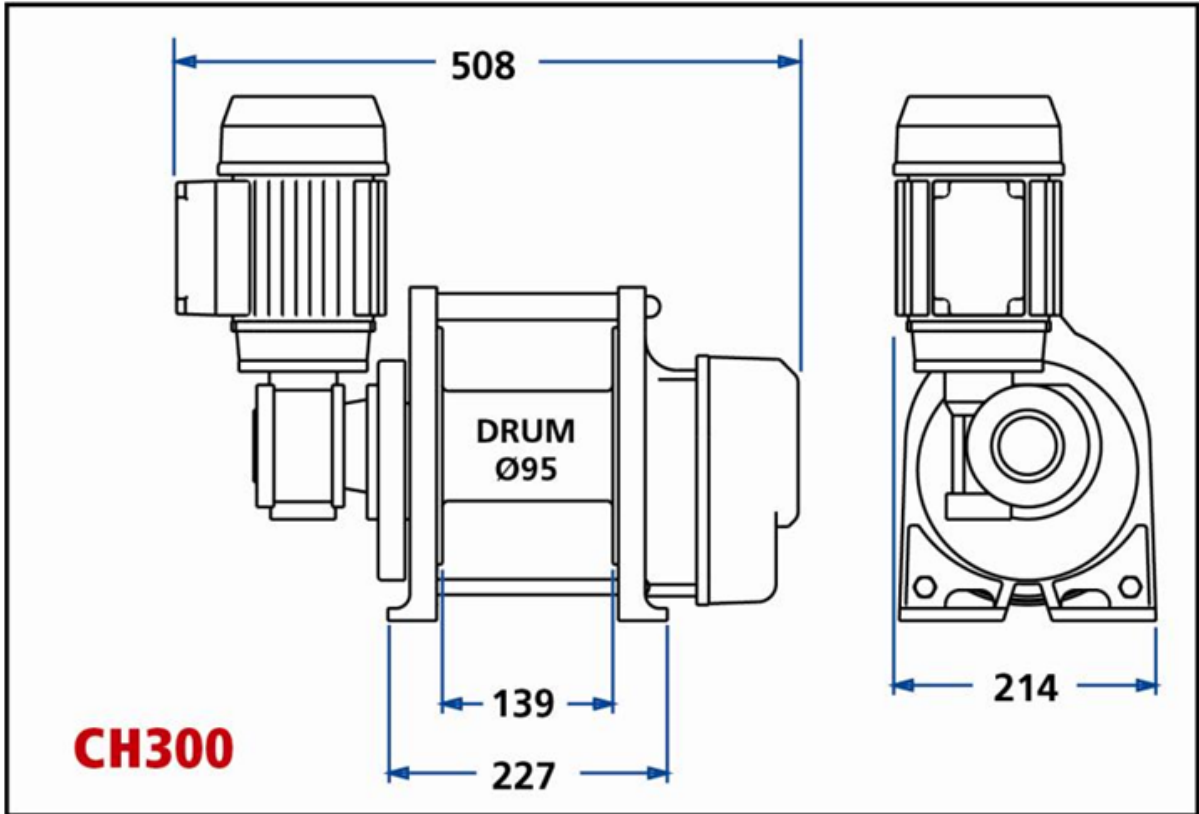

HOIST INFORMATION

HOIST PERFORMANCES

CH100 Rated Capacity 4 th Layer	NUMBER OF ROPE LAYERS ON DRUM							
	1	2	3	4	5	6	7	8
Maximum Rated Capacity - KG	135	121	110	100	92	86	80	75
Rope Capacity by Layer - M	2.5	5.4	8.5	11.9	15.5	19.5	23.8	28.3
Line Speed – M/min	3.5	4.0	4.5	5.1	5.6	6.1	6.6	7.1

CH200 Rated Capacity 3rd Layer	NUMBER OF ROPE LAYERS ON DRUM							
	1	2	3	4	5	6	7	8
Maximum Rated Capacity - KG	243	220	200	185	171	159	149	140
Rope Capacity by Layer - M	5.8	12.2	19.2	27	35	44	53	63
Line Speed – M/min	3.5	3.9	4.3	4.7	5.0	5.4	5.8	6.1

CH300 Rated Capacity 3rd Layer	NUMBER OF ROPE LAYERS ON DRUM							
	1	2	3	4	5	6	7	8
Maximum Rated Capacity - KG	364	329	300	277	256	238	223	210
Rope Capacity by Layer - M	8.8	18.5	29.1	40.6	53	66.5	81	96
Line Speed – M/min	2.4	2.6	2.9	3.1	3.4	3.6	3.9	4.1

CH600 Rated Capacity 3rd Layer	NUMBER OF ROPE LAYERS ON DRUM				
	1	2	3	4	5
Maximum Rated Capacity - KG	757	671	602	546	500
Rope Capacity by Layer - M	10	21.5	34	48	60
Line Speed – M/min	2	2.3	2.9	3.1	3.5

WINCH LABELS

<p style="writing-mode: vertical-rl; transform: rotate(180deg);">BHW227/12/11</p> 	<p>WINCH RATING</p> <p>BHW</p> <p>Bushey Hall Winchmaster</p> <p>www.bhwgroup.com</p> <p>6 South Orbital Business Park, Hedon Road Hull, East Yorkshire HU9 1NJ UK T: +44 (0)1482 223 663</p>	<p>SERIAL NO: 000000</p> <p>DATE OF MANUFACTURE: 00/00/00</p> <p>WORKING LOAD LIMIT: 00000kgf</p> <p>MAX LIFT: 00m</p> <p>ROPE Ø (mm): 00mm</p> <p>BREAKING FORCE: 0000kgf</p>
	<p>MODEL:</p> <p>VOLTAGE:</p>	

Ratings Label



Drum Direction Label

ADDITIONAL EQUIPMENT

The following pages show additional equipment that is typically used for an Chandelier winch installation. Dimensions given are nominal and intended as a guide to gauge installation space required.

CONTROL BOX Part No. 2179

For quick and easy installation of electrical circuits for the hoist, limit switches, power supply and control switches.

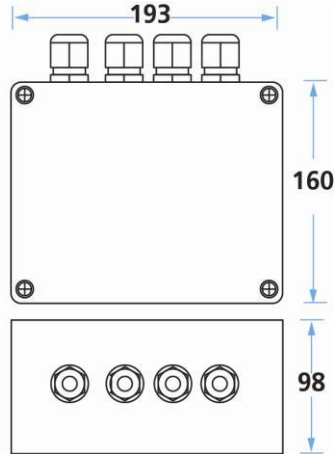

CONTROL SWITCH Part No. 9485

Hard wire control switching and isolator switches are normally sited within view of the load being raised or lowered. Use of this 'key only' access switch offers additional security and safety.

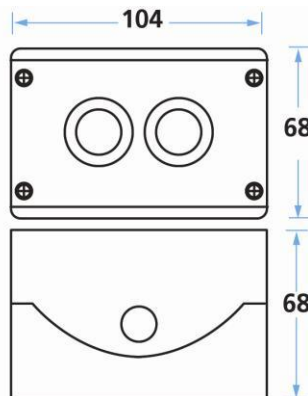

LIMIT SWITCH

Designed to set the lowest and highest parameters of the operational requirement, effectively stopping the wire rope at top and bottom heights.

There are four variants of limit switch with different ratios. Choice of switch will depend on length of fall.

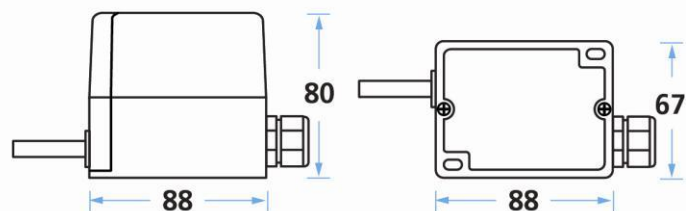

ADDITIONAL EQUIPMENT

AUTOMATIC CABLE REWINDER

Supplied certified for each individual application, based on kw and circuit information supplied by the client.

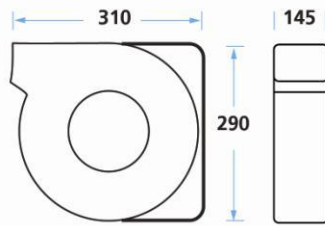

Dimensions shown are an average of all models available

DOUBLE PULLEY

Double Pulleys for wire rope and power cable applications.

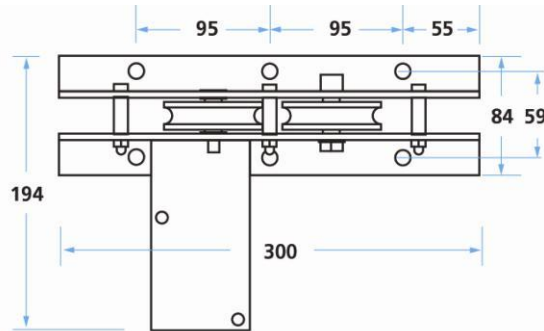
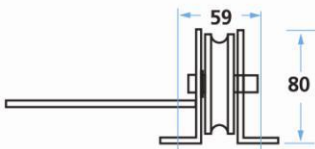

SINGLE PULLEY

Single pulleys for hoist only applications or additional routing of wire rope or power cable in the ceiling void.

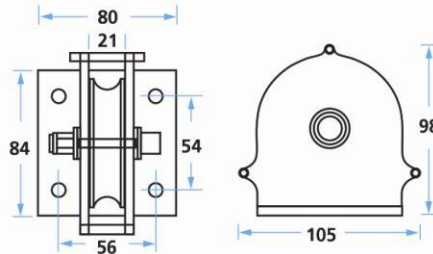

FM•CONNECT

Remote control system unique to BHW Group. Supplied with transmitter and receiver and full installation instructions.



Further accessories including connectors, bow shackles, mounting brackets and protective covers are available from BHW Group sales on (0) 1482 223 663.

INSTALLATION

PLEASE READ THIS CAREFULLY BEFORE INSTALLING OR OPERATING THE WINCH.

Respect for a winch and common sense in its operation, will ensure complete safety and reliability. Do not underestimate the potential danger in hoisting operations. Be aware of the basic dangers so you can avoid risk of accidents and unnecessary damage to the winch, the items being lifted or raised - or the surrounding environment.

Keep yourself and others at a safe distance, away from the operation of the winch when in use.

GENERAL INSTALLATION NOTES

BHW Chandelier winch have been built to a specification to comply with EN14492-2. These winches are tough and will provide many years of reliable service if being used for the correct application. Like all machines they must be installed correctly in accordance with these fitting instructions (Pages 9-14) and subsequently the user must also adopt correct and safe operational procedures.

Before installing the winch, it is important to work out what load bearing may be put into the adjacent area. A suitable support must be fitted across joists to support the load. You are advised to consult a qualified builder or structural engineer to determine these factors.

You are also advised to double check the amount of wire rope (and power cable) needed, not only for lowering and raising, but also including the length of wire rope or cable permanently off of the hoist drum as part of the installation.

INSTALLING THE WINCH & ADDITIONAL EQUIPMENT

To encourage even wire rope wrapping on the drum, the winch must be securely mounted at least at the minimum distance from the winch to the first pulley as specified on page 4. The diagram below shows a typical layout, incorporating an automatic cable re-winder.

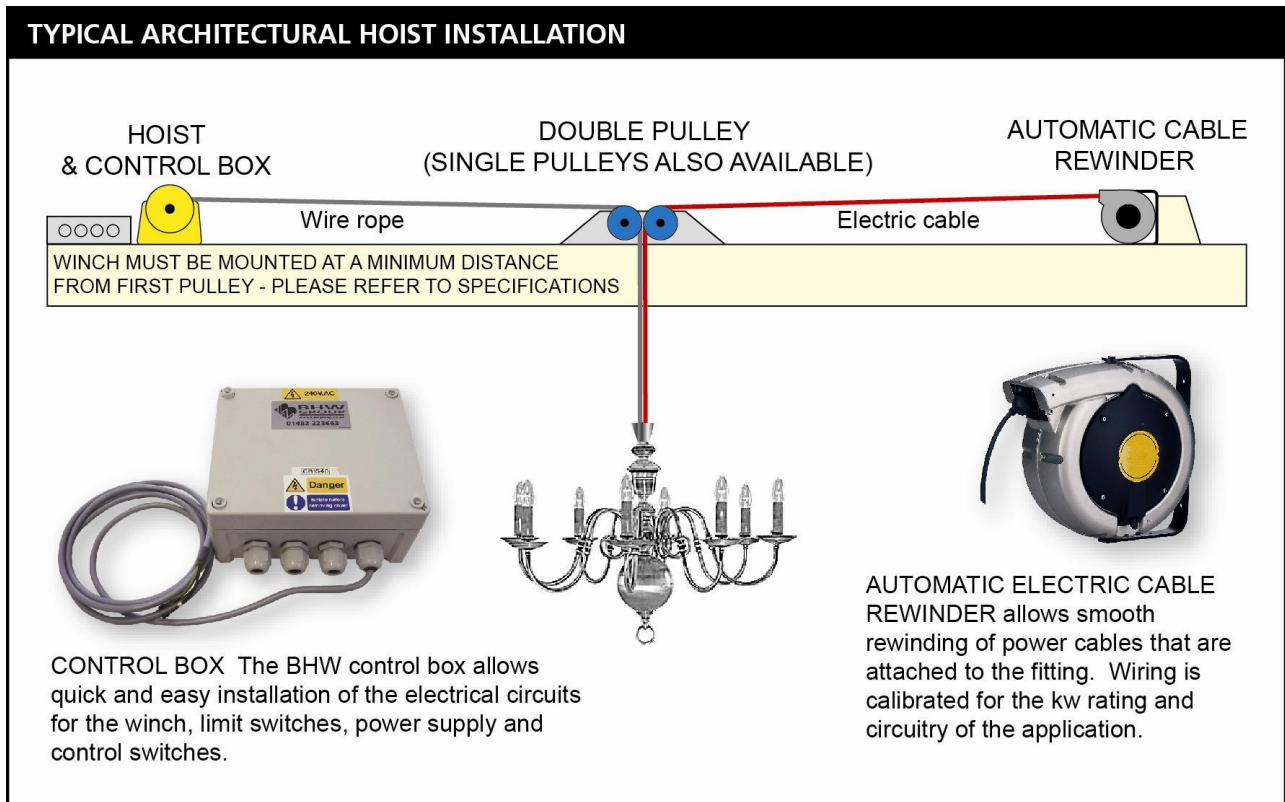

INSTALLATION

ELECTRICAL INSTALLATION

Electrical installation and any subsequent repairs should be carried out by a qualified electrician.

ELECTRICAL SAFETY



According to the Health and Safety Executive, each year there are approximately 1000 work accidents involving electric shock or burns. Around 30 of these are usually fatal.

Even non-fatal shocks can cause severe or even permanent injury. Improperly installed electrical equipment can also cause related accidents.

Electricity at Work Regulations (1989) requires adequate precautions to be taken against the risk of death or injury from electricity during work, at or near electrical installations.

Installations in private dwellings must be certified by a fully qualified electrician and fully tested and certified. Failure to do so may invalidate insurances and warranties.

Please determine the electrical requirements for the application prior to any work as insufficient installation standards will result in damage to the hoist and possibly put operatives in danger.

Always ensure the correct 240v voltage corresponding to the hoist electrical system is used and protected by suitable circuit breakers. Power provided should be at 50Hz.

Additional equipment to be used in the installation that requires power (i.e. Power Cable Rewinder) must also be protected by circuit breakers and suitably earthed.

It is ultimately the responsibility of the person installing the hoist system to carry out a risk assessment to decide and if necessary provide any additional emergency stops, isolators or circuit restrictions suitable for the application.

INSTALL A FUSED ISOLATION SWITCH

It is important to fit a fused isolation switch in the power supply line to the winch.

IN LINE OPERATIONAL CONTROLS

Further in-line operational controls that are on view can use rocker type switches, the bias of the rocker switch should be to the OFF position.

A lockable in-line switch (See Switch Control, page 7) may be deemed necessary if there is a risk of unauthorised personnel gaining access to the working area.

Operational controls should be positioned so that the winching operation is clearly in view.

Alternatively a remote control system may be fitted (See FM•Connect, page 7). Further details are available from the BHW Group sales team on (0) 1482 223 663.

INSTALLATION

WIRING DIAGRAM – STANDARD ELECTRICAL INSTALLATION CH100, CH200 & CH300

A copy of this diagram can be found on the inside of the lid of the control box.

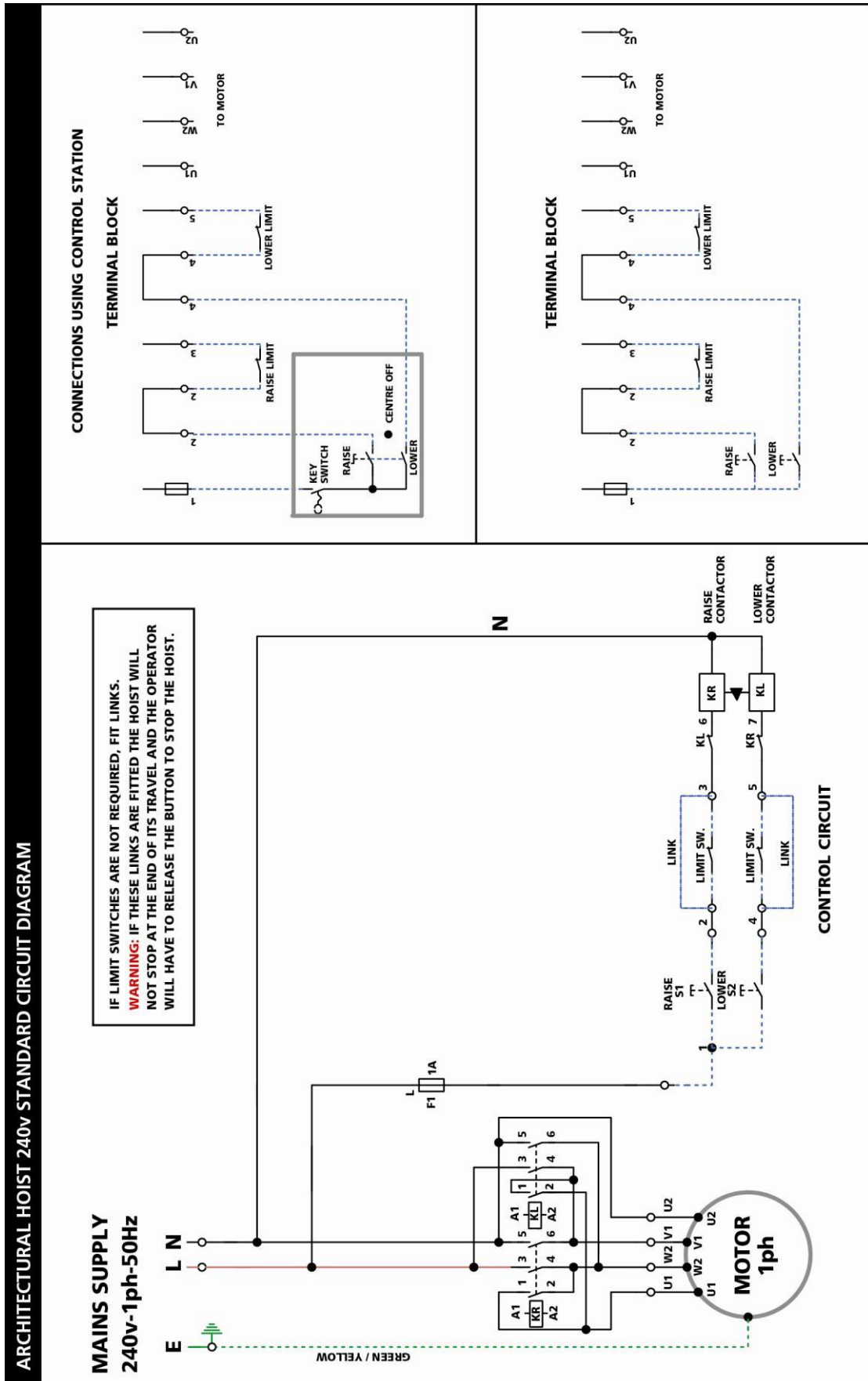

CONNECTIONS USING CONTROL STATION

TERMINAL BLOCK

TO MOTOR

LOWER LIMIT

RAISE LIMIT

KEY SWITCH RAISE LOWER CENTRE OFF

TERMINAL BLOCK

TO MOTOR

LOWER LIMIT

RAISE LIMIT

RAISE LOWER

INSTALLATION
WIRING DIAGRAM – CH600

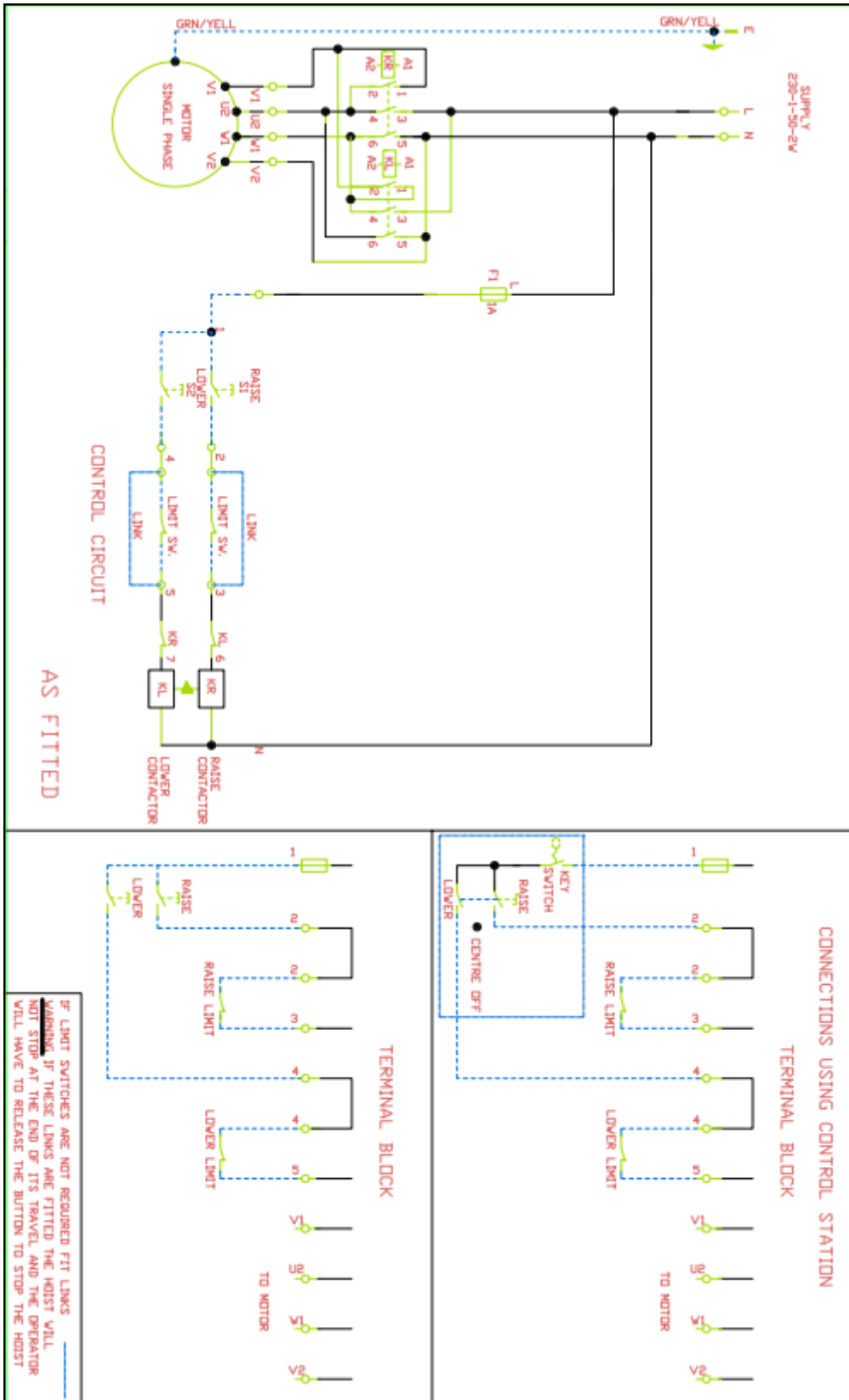

INSTALLATION

WIRING DIAGRAMS – CH600 Junction Box

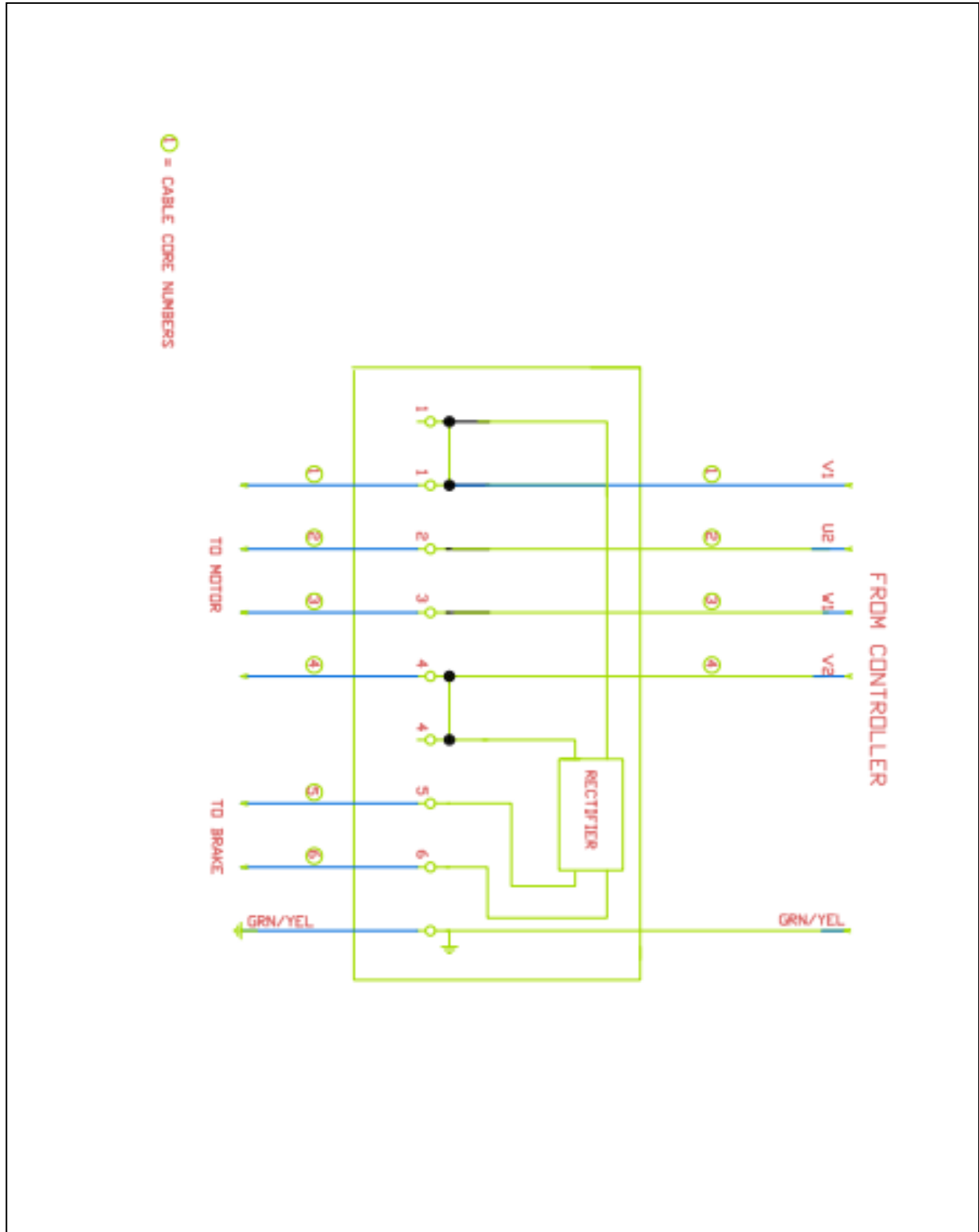

INSTALLATION

WIRING DIAGRAMS – Low Voltage Control

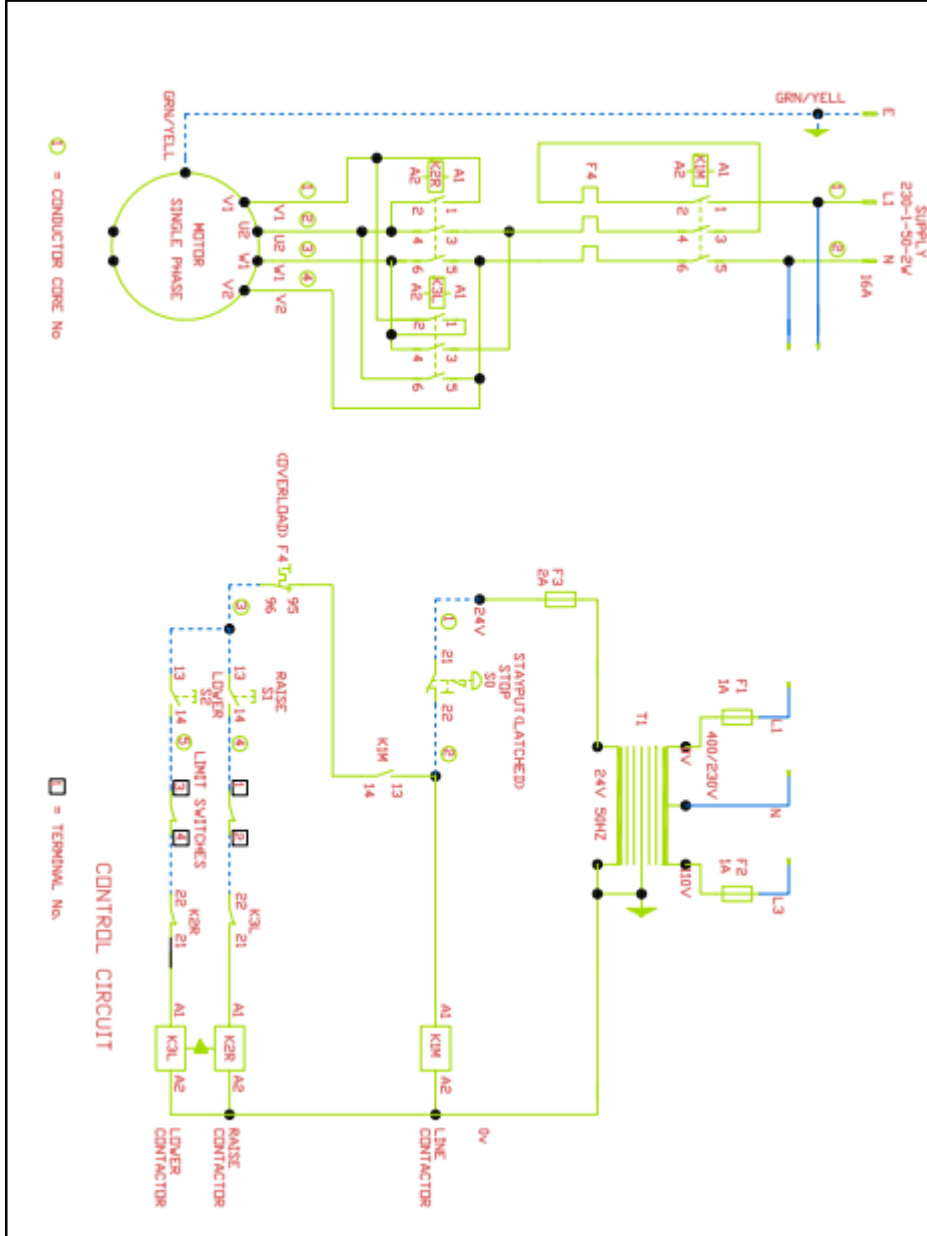

INSTALLATION

WINCH ROTATION **VERY IMPORTANT**

On models CH100, CH200 and CH300, the wire rope is fed over the top of the drum and 'winch in' direction is anti-clockwise when viewed from the motor end.

On model CH600 the wire rope can be fed on to the drum over or under. In button may require changing to suit application

FITTING THE WIRE ROPE

Once the winch has been installed and all fixtures have been secured, the wire rope can be installed. Always wear protective gloves when handling the wire rope.

A spin resistant wire rope of the correct specification (as detailed on page 4) should be used according to the winch chosen for the application.

Please note that wire ropes supplied from BHW Group are designed as 'fit for the purpose' for the winch and the application. Wire ropes that are not purchased from our company cannot be guaranteed to give the same results - and may affect the performance of the winch.

TO FIT THE WIRE ROPE TO THE DRUM

Thread the plug end of the wire rope through the ceiling aperture into the ceiling void from the room below. After feeding through pulleys that are in line, the wire rope should then be attached to the hoist as follows:

1. On the drum of the hoist is a small hexagonal grub screw next as part of the aperture designed for the wire rope entry. Remove this grub screw and retain for replacement.
2. Insert the plug end of the wire rope into the drum and slide sideways to secure.
3. The grub screw that has been retained can then be re-inserted into its original position to secure the wire rope. Ensure that the grub screw is tight and flush with the drum surface.
4. The wire rope can now be wound on to drum. Keep tension on the wire rope at all times. Wear protective gloves when handling the wire rope.

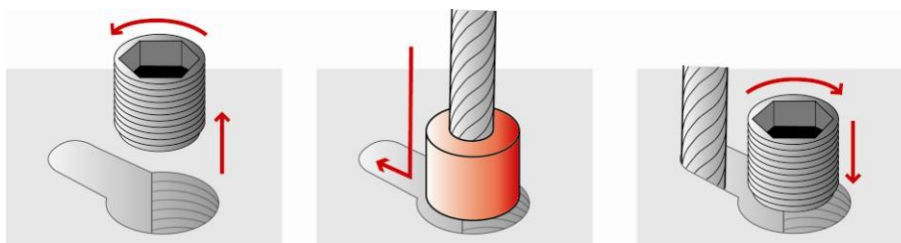

TESTING THE HOIST

NEVER STAND UNDERNEATH THE LOAD WHEN OPERATING THE WINCH

Load test the hoist following installation to check the integrity of the application and correct operation of the winch by using a weighted object (not the load or fixture). The weight used for the load test should be at least 125% of the proposed load to be lifted.

Carefully check all fixtures and supporting frameworks or joists. Double check all wiring connections.

ATTACHING THE PROPOSED LOAD

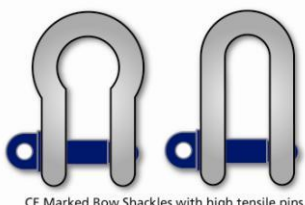

Attaching the wire rope to the load should use a suitable connector such as an industrially rated and CE marked high tensile bow shackle. All connectors should be rated for lifting by at least a safety factor of 4:1. Example: A 500kg (0.5 tonne) connector has a maximum yield of $0.5 \times 4 = 2$ Tonne.

Information on height limit switches can be found on the next page.

INSTALLATION

SETTING A LIMIT SWITCH

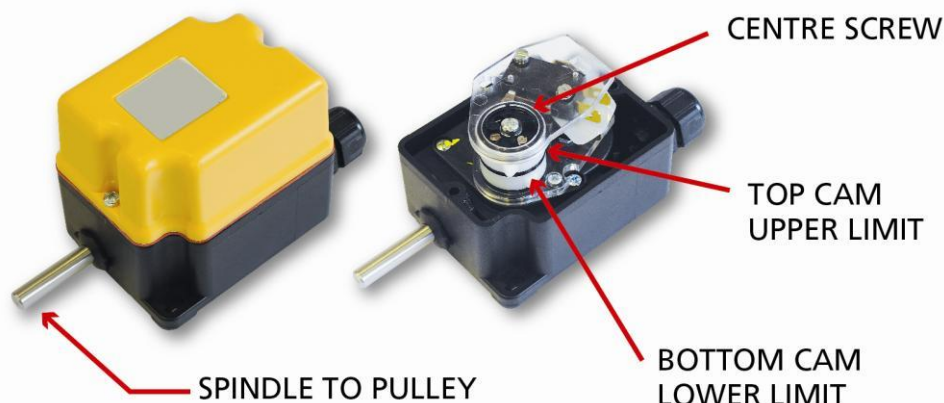

If a limit switch is fitted into the installation, the highest and lowest points of operation can be pre-set. Suitable limit switches are available from BHW Group.

TO CONFIGURE THE LIMIT SWITCH

1. The wire rope fitted to the winch drum should ALWAYS retain a minimum of 7 wraps, even when fully paid out.
2. The remainder of the rope can be lowered to the length required (also allowing for load depth) through the ceiling aperture to the floor below. Check that there is still enough wire rope left on the drum to comply with instructions above.
3. Once this length has been determined, loosen the CENTRE SCREW on the limit switch and adjust BOTTOM CAM (LOWER LIMIT) clockwise until the cam trips the switch.
4. Tighten the CENTRE SCREW.
5. Raise the wire rope until the highest desirable point of operation is achieved.
6. Loosen the CENTRE SCREW and turn the TOP CAM (UPPER LIMIT) clockwise until the cam trips the switch.
7. Tighten the CENTRE SCREW.
8. Run the operation 2-3 times without the final load (use a test weight of at least 15g to tension the rope) and double check highest and lowest limits. Adjust as necessary repeating the procedures above.
9. Fix the operational load and check limits again, adjust as necessary. You are advised to place suitable protection on the floor under the load to help prevent any damage.

NOTE: WHEN SETTING LIMIT SWITCHES IT IS IMPORTANT TO RETAIN AT LEAST 7 WRAPS OF WIRE ROPE ON THE DRUM WHEN FULLY PAID OUT. FAILURE TO DO SO MAY OVERSTRESS THE RETAINING PLUG ON THE END OF THE WIRE ROPE INSIDE THE DRUM AND CAUSE THE WIRE ROPE TO BECOME UNATTACHED.

ALWAYS USE SPIN RESISTANT WIRE ROPES TO THE CORRECT SPECIFICATION FOR THE WINCH BEING USED.

MAINTENANCE

LOOK AFTER THE WINCH

Check that the winch, the housings and any additional equipment is free from debris and dust. Protective covers are recommended and available from BHW Group sales – call (0) 1482 223 663.

Always make sure that tension is applied to the wire rope. This is to ensure that the wire rope can wind neatly and evenly on to the drum. The load that is being lifted or raised is normally enough to ensure this if the required distance from the winch to the first pulley has been observed (See page 4).

Loose coils or uneven wrapping are dangerous and can result in trapping or snatching on the drum when next used - and can also cause damage to the wire rope or the winch.

Do not allow the any additional restraint on the load to cause extra load on the hoist during a lift, as this can momentarily double or even treble the load on the wire rope.

OPERATE THE WINCH FROM TIME TO TIME

Due to the nature of the application of Chandelier winch, they are not constantly in use. It is recommended that the winch(s) be powered in and out from time to time to minimise corrosion of the internal motor components that may occur due to condensation. Energising the motor will generate heat, which will help dissipate any moisture.

CHECK THE ADDITIONAL EQUIPMENT

Any additional equipment employed in the winch system should be regularly checked and maintained. This includes greasing of the pulleys used, checking mountings and cables and generally ensuring that the system is free from debris or dust.

CARE OF THE WIRE ROPE

It is most important that the wire rope is inspected on a regular basis, for kinks, flat spots, broken strands and other damage. If necessary the wire rope should be replaced. Always use a spin resistant wire rope of a suitable breaking strain. Reset the limit switch if fitted, as the calibration of the old wire rope will not be retained.

Oil and grease should never be used on wire ropes.

CHECK THE WIRE ROPE and replace under any of the following circumstances:

- 10 strands of rope or more broken with a space of 25mm (See fig.1).
- Rope shows visible signs of wasting (See fig.2).
- Deformed or excessively corroded rope.
- Twisted rope.
- Bent rope.

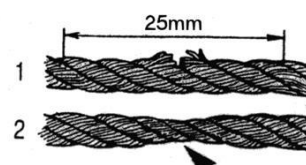

Remember; always wear protective gloves when handling wire ropes.

WIRE ROPES ARE NOT COVERED BY WARRANTY.

MAINTENANCE

REGULAR MONTHLY MAINTENANCE

The winch should be kept clean in order to prevent any build-up of corrosion or debris on external working parts. Protection covers are available from BHW Group to help prevent dust and debris ingress.

- Check winch for any external damage.
- Check winch fixtures for any movement and re-tighten or replace fixings as necessary.
- All external-moving parts should be lubricated with lightweight oil (except the wire rope).
- All electrical connections and wiring should be inspected for loose connections, corrosion, fraying or pest damage.
- Check the raising and lowering of the load to ensure that the winch is functioning properly.
Make sure that personnel are well away from the operation. Never stand under the load when operating the winch.

CHECK THE CONNECTION TO THE LOAD

- Check that any connector used to attach the load is secure and fit for purpose.
Replace if any excessive wear and tear or damage is identified.

LUBRICATION

BHW Chandelier winches are fully lubricated at the time of assembly and do not require lubrication before use. If at a later stage lubrication is necessary, 460 grade 30/40w oil should be used. The average fill quantity is approximately 300ml.

SERVICE & PARTS REPLACEMENT

BHW Chandelier winch should be serviced according to duty cycle or after any damage or system change.

As the CH100, CH200, CH300 & CH600 models are not user serviceable, you are advised to contact BHW Group to arrange for professional servicing of the winch(s).



WINCH PARTS

CH100

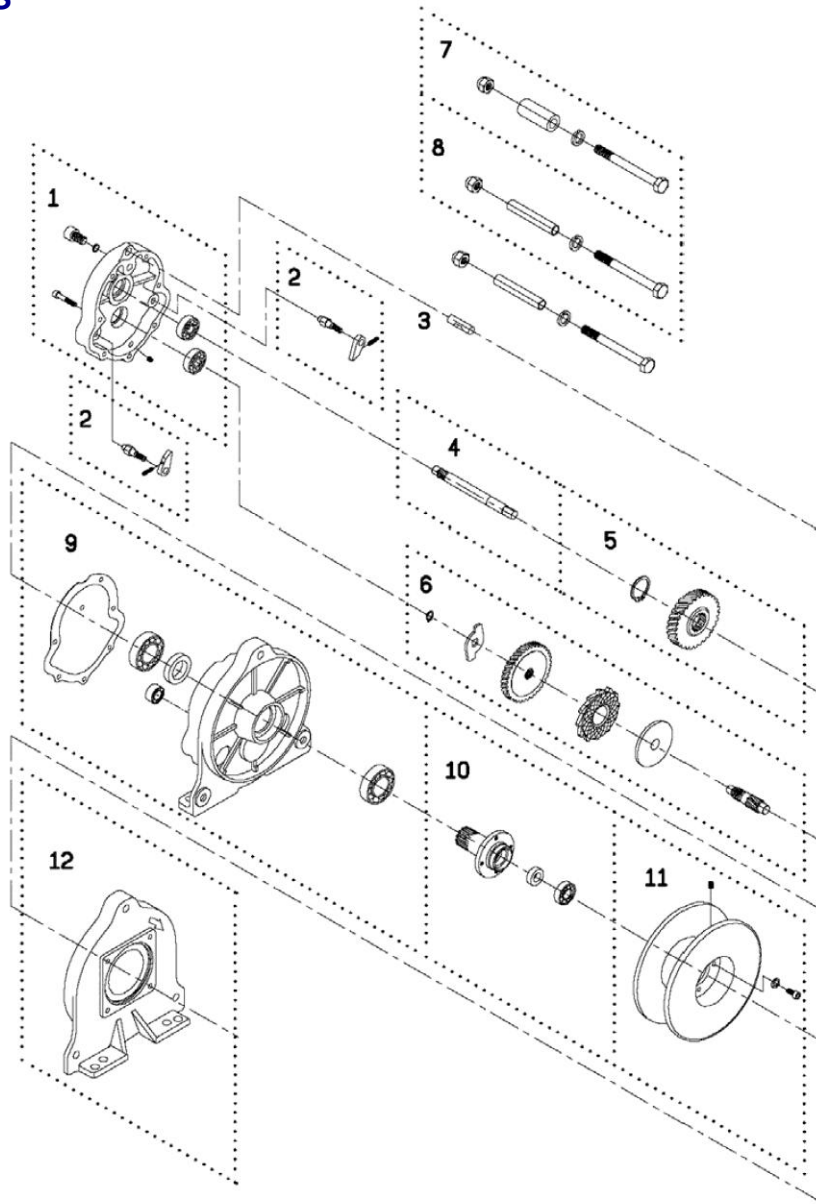

CH100			
Item no.	BHW Part No.	Description	QTY
1	13846	Gearbox Rear Cover Kit	1
2	13847	Ratchet stopper kit	2
3	13848	Balancer Indicator	1
4	13849	1st shaft kit	1
5	13850	2nd gear kit	1
6	13851	Brake kit	1
7	13852	Tie bar kit	1
8	13853	Tie bar kit A	2
9	13854	Gearbox support rack kit	1
10	13855	Output shaft kit	1
11	13856	Drum Kit	1
12	13857	Motor support kit	1
13	2616	Motor adaptor plate	1
14	8450	Coupling drive shaft	1
15	10767	Motor 240v 0.13kw IP55	1
n/s	2059	Bolt M6 x 25mm H/T 8.8 BZP	4
n/s	3373	Washer M6 plain ZP	4
n/s	3374	Washer M6 Spring ZP	4
n/s	2051	Bolt M5 x 20mm panhead slot M/T screw	4
n/s	3372	Washer M5 spring ZP	4
n/s	2875	Label " Arrow " drum rotation	1

WINCH PARTS

CH200

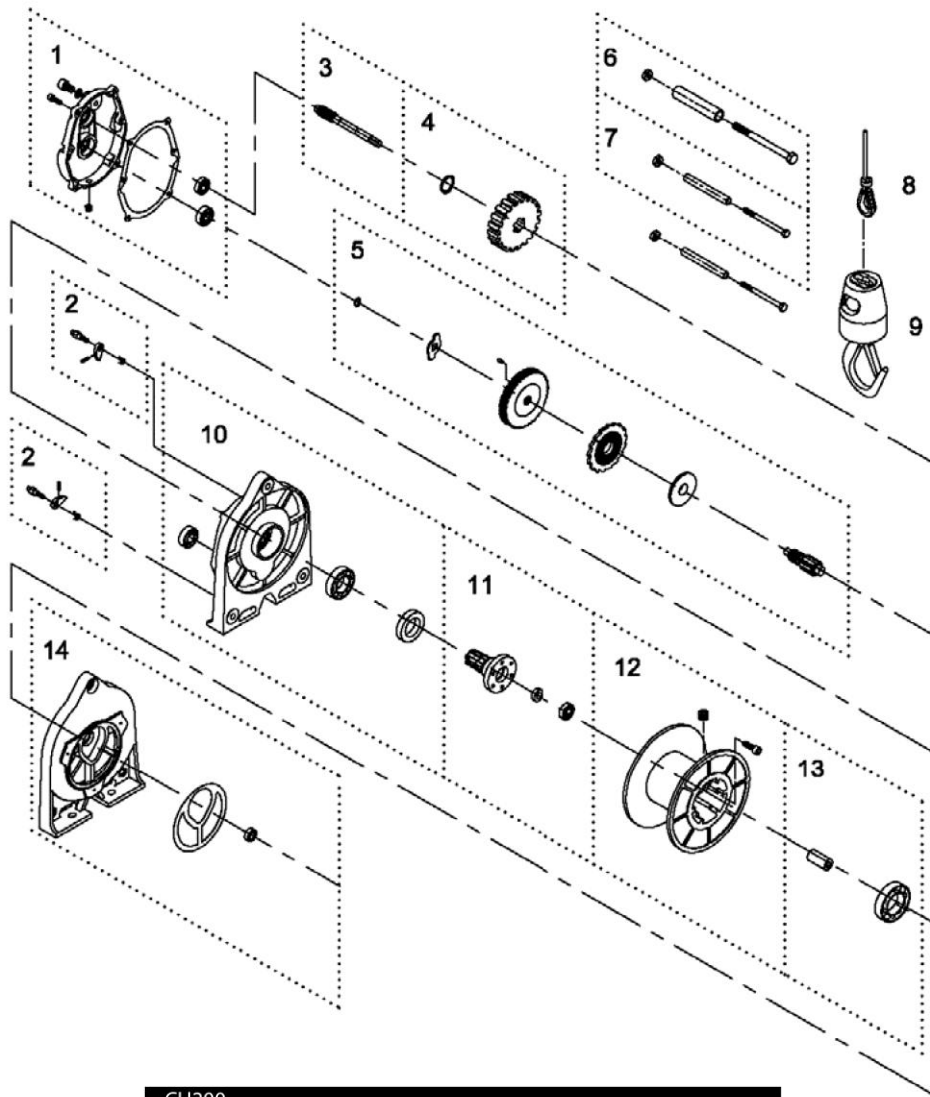

CH200			
Item no.	BHW Part No.	Description	Qty
1	13858	Gearbox Rear Cover Kit	1
2	12859	Ratchet stopper kit	2
3	13860	2nd shaft	1
4	13861	3rd gear kit	1
5	13862	Brake kit	1
6	13863	Tie bar kit	1
7	13864	Tie bar kit A	2
8	Options	Wire rope	1
9	Options	Weighted hook	1
10	13865	Gearbox support rack kit	1
11	13866	Output shaft kit	1
12	13867	Drum kit	1
13	13868	Motor coupling kit	1
14	13869	Motor support rack kit	1
15	8478	Motor adaptor plate	1
16	8476	Auxilliary gearbox 7:1	1
17	8479	Drive shaft	1
18	10256	Motor 240v 0.37kw	1
n/s	2058	Bolt M6 x 20mm H/T 8.8 BZP	4
n/s	2059	Bolt M6 x 25mm H/T 8.8 BZP	3
n/s	2069	Bolt M8 x 25mm H/T 8.8 BZP	4
n/s	3373	Washer M6 plain ZP	3
n/s	3375	Washer M8 plain ZP	4
n/s	2875	Label " Arrow " drum rotation	1

WINCH PARTS

CH300

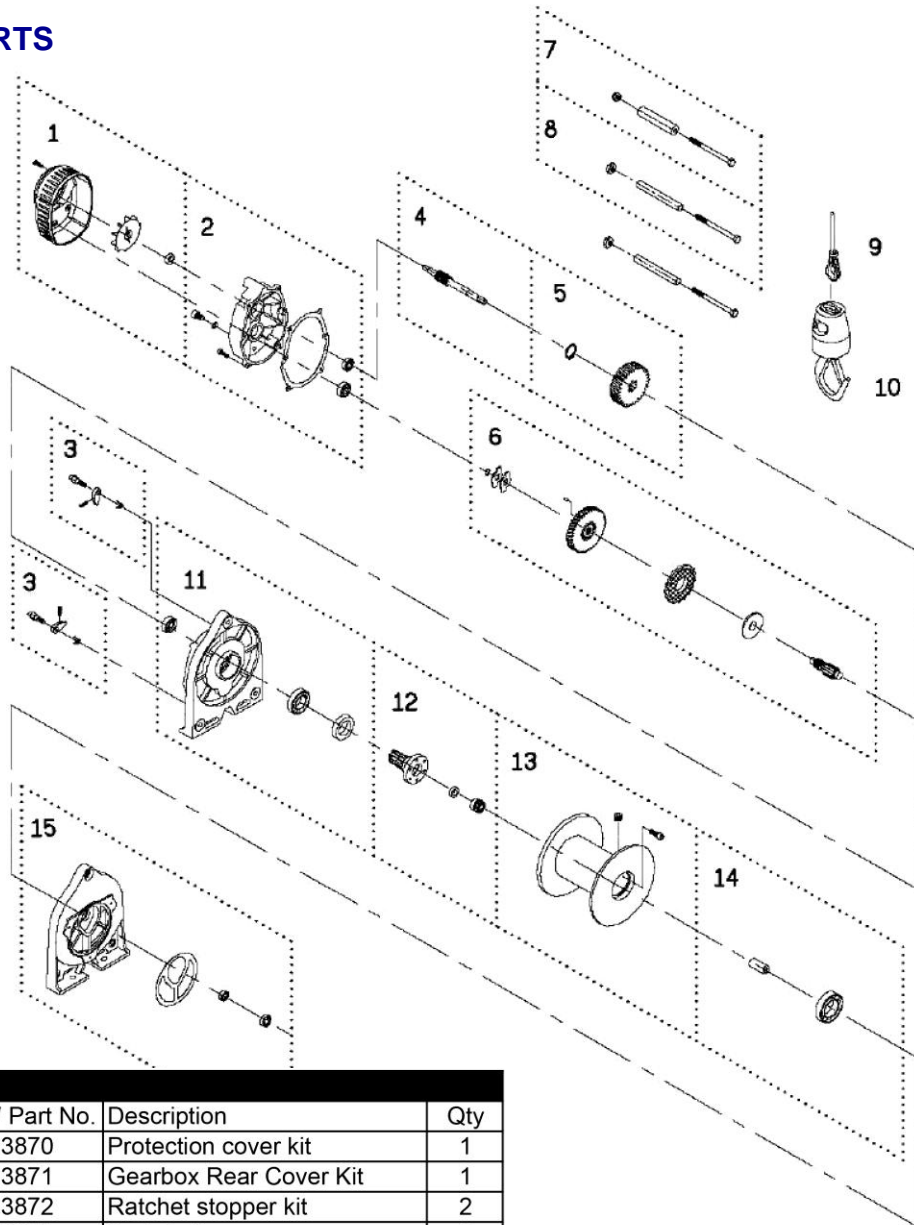

CH300			
Item no.	BHW Part No.	Description	Qty
1	13870	Protection cover kit	1
2	13871	Gearbox Rear Cover Kit	1
3	13872	Ratchet stopper kit	2
4	13873	2nd shaft	1
5	13874	3rd gear kit	1
6	13875	Brake kit	1
7	13876	Tie bar kit	1
8	13877	Tie bar kit A	2
9	Options	Wire rope	1
10	Options	Weighted hook	1
11	13878	Gearbox support rack kit	1
12	13866	Output shaft kit	1
13	13879	Drum kit	1
14	13868	Motor coupling kit	1
15	13869	Motor support rack kit	1
16	8478	Motor adaptor plate	1
17	8476	Auxilliary gearbox 7:1	1
18	8480	Drive shaft	1
19	10257	Motor 240v 0.37kw	1
n/s	2058	Bolt M6 x 20mm H/T 8.8 BZP	4
n/s	2059	Bolt M6 x 25mm H/T 8.8 BZP	3
n/s	2069	Bolt M8 x 25mm H/T 8.8 BZP	4
n/s	3373	Washer M6 plain ZP	3
n/s	3375	Washer M8 plain ZP	4
n/s	2875	Label " Arrow " drum rotation	1

WINCH PARTS

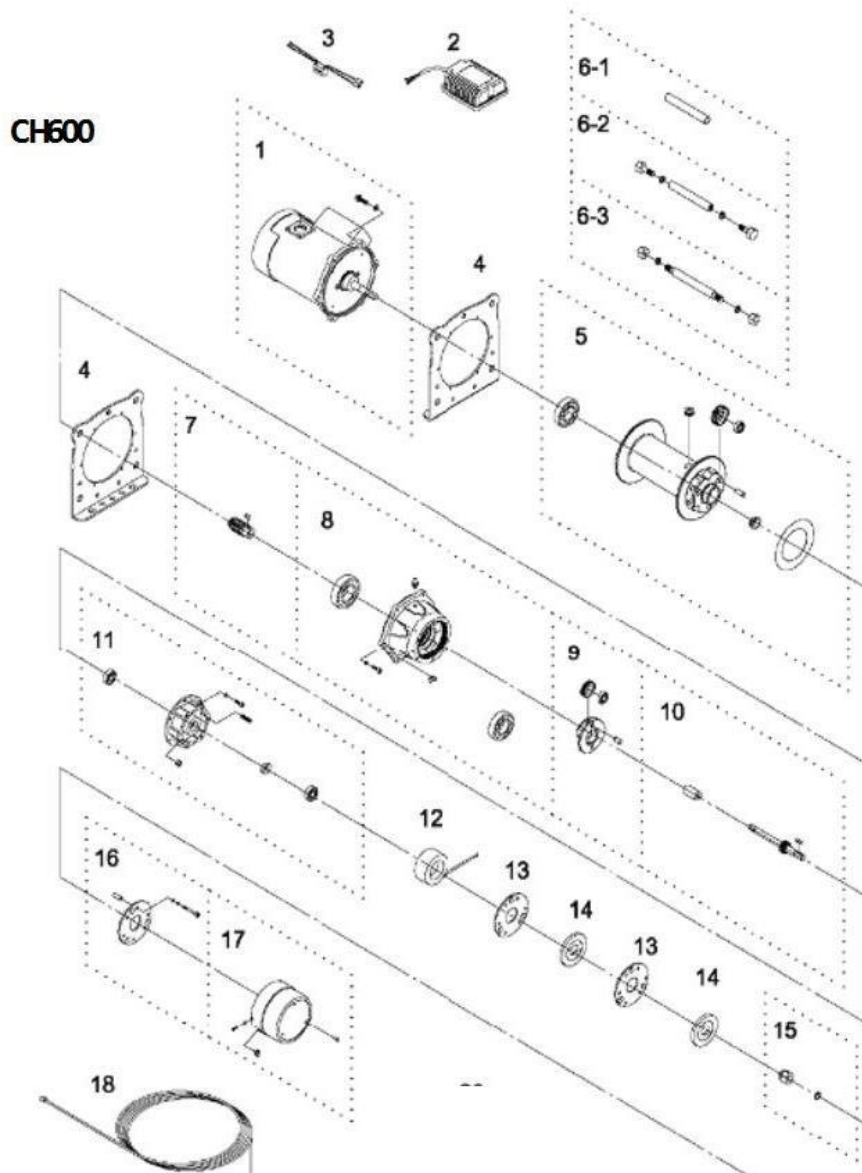

Parts description - CH600

No.	BHW no.	Description	Qty	No.	BHW no.	Description	Qty
1	12542	Induction motor 240v 50Hz	1				
n/s	12541	Aux gearbox 7:1	1	10	13280	1st Shaft kit	1
2	12661	Junction box	1	11	13281	Conductor kit	1
3	8969	Bridge rectifier CBR-072	1	12	13260	Brake coil 240v	1
4	13272	Support bracket	2	13	13282	Conductor plate A	2
5	13273	Drum kit	1	14	14344	Brake disc	2
6..1	13274	Tie bar	1	15	13284	Hex socket	1
6..2	13275	Tie bar kit	2	16	13285	Conductor plate A kit	1
6..3	13276	Tie bar kit	2	17	13286	Brake cover	1
7	13277	2nd Shaft kit	1	18	3502	Wire rope 7mm x 30m	1
8	13278	Gearbox kit	1	n/s	12543	Adaptor plate	1
9	13279	1st Stage carrier	1	n/s	12544	Drive shaft	1

WARRANTY

BHW GROUP LIMITED warrants each new winch and additional equipment supplied against factory defects in material and workmanship for one year from date of purchase.

The responsibility for removing the winch or equipment is the owner's together with its return and transportation prepaid to BHW Group Limited.

BHW Group Limited will, under this warranty, without charge, repair or replace at its option, parts, which on inspection are deemed to be defective. The losses of use of the produce, loss of time, inconvenience, commercial loss or consequential damages are not covered.

Warranty does not apply where the product has been tampered with or altered in any way, or where the serial number or date stamp has been defaced, altered or removed, or if in the view of BHW Group Limited the damage or failure occurred from misuse, negligence or accident.

THIS WARRANTY EXCLUDES THE WIRE ROPE

BHW Group Limited reserve the right to change the design of any product without assuming any obligation to modify any product previously supplied.

Winches or equipment returned under warranty should be despatched to BHW Group Limited service department at the address shown below, with full name and address of sender, a statement detailing the defect and proof of purchase.



Service Department
Bushey Hall Winchmaster
6 South Orbital Trading Park
Hedon Road, Hull, HU9 1NJ

Telephone: +44 (0)1482 223 663
Fax: sales@bhwgroup.com
Website: www.bhwgroup.com

CHANDELIER WINCH – TYPE & RATING.....
SERIAL NUMBER.....
DATE OF PURCHASE.....