



Heavy Duty Hoist [#2333 / #2334] Model: ***DH-120, 12V/24V***

Introduction

► Feature

Lifting capacity:	120 kg
Lifting height:	5 m
Lifting speed:	5 M/min
Motor output:	100W x 15A at DC12V
Brake:	Electromagnetic and mechanical ratchets
Control:	Pendant switch powers the hoist

► Unpacking

- Hoist assembly..... 1pc
- Pendant switch CPB-271 w/cords..... 1pc
- Wire rope 4 mm x 5 m w/safety hook..... 1pc

► Read this manual carefully

You should carefully read and understand this manual before operating it. Careless hoist operation may result in personal injury hazards or property damage.

► Information requesting or parts ordering

Please specify the followings information:

- Hoist PN
- Serial number
- Part description
- Replacement part number
- Quantity for each part

Installation

Before using the hoist, make sure all electrical components have no corrosion or damaged; the environment should be clear and dry.

► Wire rope replacement

- Insert the wire rope into the hole of drum and fix it with a P. T. screw, then press the "UP" button of switch for rotate the drum in the lifting direction.
- Wind the wire rope accurately around the drum, and an irregular winding will cause the load to be swing, thus damaging the wire and reducing the life of hoist.

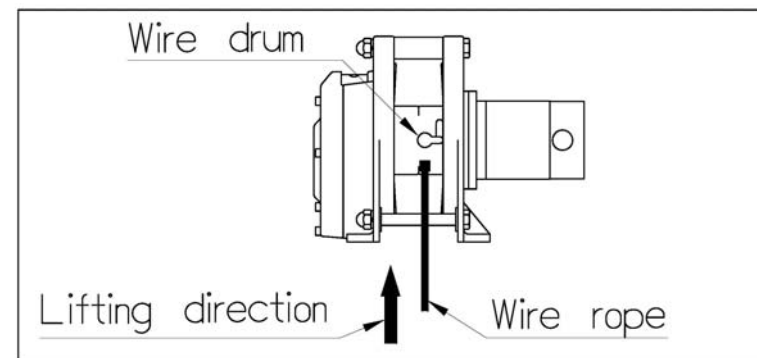

► Wiring Diagram

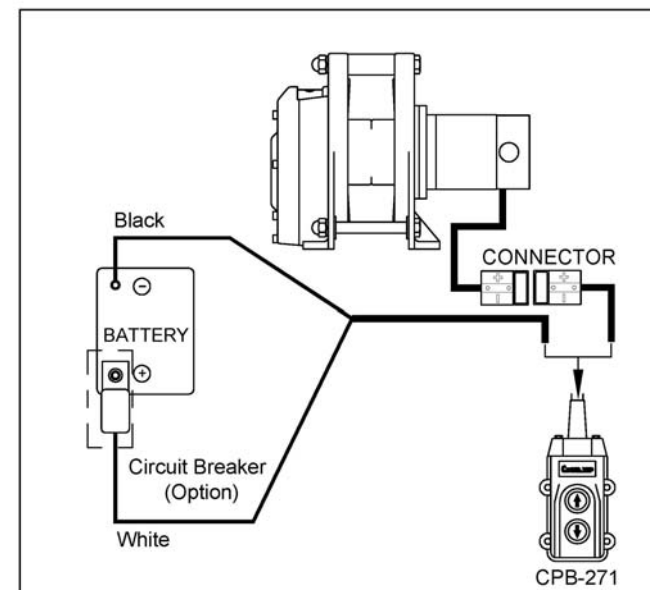

Warning

- The hoist is not intended to be used in any manner for the movement or lifting of personnel.
- The lifting capacity shown is based on the top layer of rope on the drum.
- The rope winding on the drum shall remain 5 wraps from the drum.

Parts List

Item No.	Description	Part No.	Qty
1	Gearbox rear cover kit	880520	1
2	Ratchet stopper kit	880547	2
3	Balancer indicator	880522	1
4	1 st shaft kit	880523	1
5	2 nd gear kit	880524	1
6	Brake kit	881496	1
7	Tie bar kit	880527	1
8	Tie bar kit A	880528	2
9	Gearbox support rack kit	880531	1
10	Output shaft kit	880532	1
11	Drum kit	880533	1
12	Motor support rack kit	880534	1
13	Motor coupling	881495	1
14	Motor kit 12V	881921	1
15	Remote control, CPB-271	881924	1
16	Wire rope w/hook	881925	1

BHW
Bushey Hall Winchmaster
www.bhwgroup.com

Bushey Hall Winchmaster sales@bhwgroup.com www.bhwgroup.com
Southern Office: Lismirrane Industrial Park, Elstree Road, Elstree, Herts, WD6 3EE Tel: +44 (0)20 8953 6050
Northern Office: 6 South Orbital Trading Park, Hedon Road, Hull, East Yorkshire, HU9 1NJ Tel: +44 (0)1482 223 663
Bushey Hall Winchmaster is a division of BHW Group Limited. Registered in England No. 1342461 VAT No. 301 7915 80

Hoist Assembly

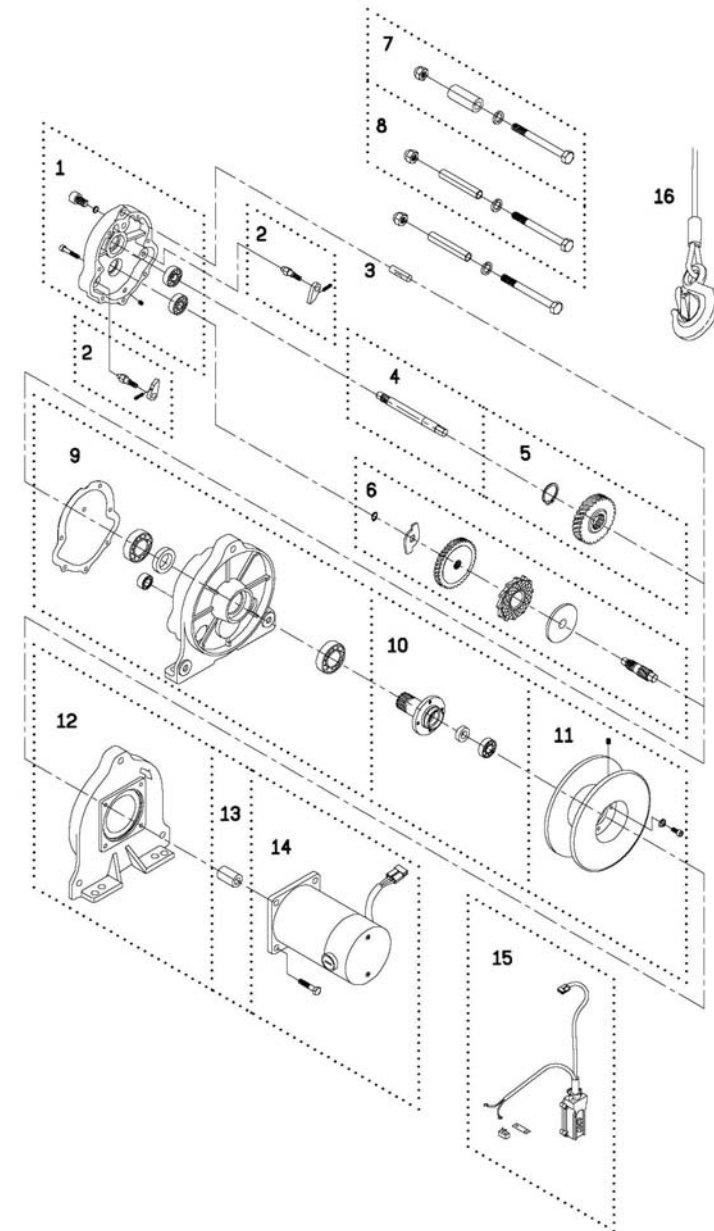

Ver:5

