

BHW

Bushey Hall Winchmaster

www.bhwgroup.com

FM • CONNECT

FM Radio Control System for Vehicle and AC Applications



The **FM-CONNECT** Radio Control System can be used in conjunction with the **BHW REEL•SMART** winch system – which guarantees straight line pull and even rope wrapping on slide bed vehicles – ask BHW sales for details.

INSTALLATION INSTRUCTIONS

Bushey Hall Winchmaster sales@bhwgroup.co.uk www.bhwgroup.com

Southern Office: Lismirrane Industrial Park, Elstree Road, Elstree, Herts, WD6 3EE Tel: +44 (0)20 8953 6050 Fax: +44 (0)20 8207 5308

Northern Office: 6 South Orbital Trading Park, Hedon Road, Hull, East Yorkshire, HU9 1NJ Tel: +44 (0)1482 223 663 Fax: +44 (0)1482 218 285

Bushey Hall Winchmaster is a division of BHW Group Limited. Registered in England No. 1342461

REMSA



CERT. No. 1769

Components included in the FM•CONNECT kit



PART NO.	DESCRIPTION	QUANTITY
4841	ANTENNA	1
4835	TRANSMITTER	1
4837	RECEIVER with 300mm cable and plug	1
4880	3m POWER CABLE	1

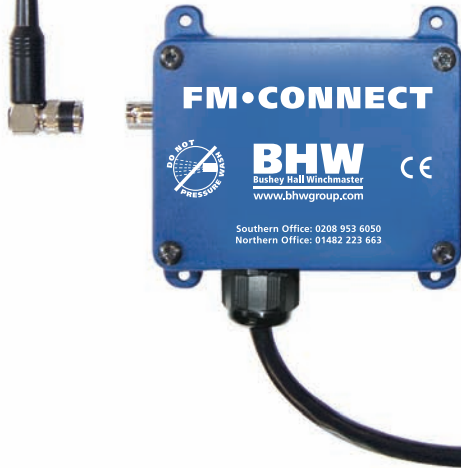

***** VERY IMPORTANT *****

These instructions must be read thoroughly before starting installation as failure to do so can result in electrical damage to this product. There are guidelines for Vehicle Applications and AC Applications depending on use. The Installer must decide before installation on the function of the 'STOP BUTTON' on the transmitter, as this will determine the wiring of the receiver. For explanation and guidance see Page 4, under 'STOP BUTTON ' INFORMATION'

CONTENTS

PAGE

Important Stop Button Information	4
Notes on Hydraulic and DC Electric Winches	4
Wiring Options Vehicle & AC - Introduction	4

VEHICLE APPLICATIONS

Disconnecting the Power Supply	5
Inside the Receiver	6
Mounting the Receiver	6
Key to Wires from the Receiver	6
Wiring Option A - Electric DC Winches - Standard as Supplied	7
Wiring Option B - Electric DC Winches with Power Cut Off Solenoid (ESK 013)	8
Wiring Option C - Hydraulic Winch with Control Valve Incorporating Dump Valve	9
Wiring Option D - Hydraulic Winch with Separate Dump Valve	10
Re-Connecting the Power Supply	11

AC APPLICATIONS

AC Wiring Option	11-13
------------------------	--------------

GENERAL INFORMATION

Recoding the Receiver to a new Transmitter if replaced	14
Transmitter Battery Replacement and Warranty Information	15
Trouble Shooting Information	16
EU Declaration of conformity	16

Stop Button Information

The system is supplied using wiring option A – (as standard supply for electric and hydraulic systems). Pressing the STOP button sends signals that will override all other signals cutting the power to the receiver and closes down all FM-CONNECT signals to the winch controls.

NOTE: In the unlikely event that winch control solenoids are jammed in the closed position, the winch will continue to operate. The only way to stop operation is to cut off the power supply. The addition of an extra solenoid in the winch control system, will enable the Transmitter STOP button to shut down the winch function. Additional products to achieve this are available from BHW Group – call sales on 020 8953 6050.

Hydraulic Winches

An electrically operated hydraulic dump valve can be included in the circuit. This can be a separate stand-alone dump valve, or a section that is integrated into the winch electric control valve. If a BHW Electric Control Valve is being incorporated in the installation, the FM Connect receiver can be pre-wired into the valve electric control system prior to supply if requested.

Electric DC Winches

It is necessary to include into the power supply cable to the control solenoids, a separate Safety Solenoid. This is required because the winch will continue to operate if the winch IN or OUT operating solenoid is at fault preventing the winch from stopping when the operating button is released. The part numbers are either 4272 (12v) or 4273 (24v). They are wired in series before the winch operating solenoids. Including this item creates a circuit enabling the power supply to be switched on to the winch simultaneously, as the IN and OUT winch solenoids are operated.

Electric AC Winches

For wiring details for low voltage controls on 1ph and 3ph AC Winches, see pages 11 & 12 (AC Winch Applications).



VEHICLE APPLICATIONS

WIRING OPTION A (Page 7) Electric DC Winches Standard as Supplied

IMPORTANT NOTE: This circuit does not include a power shut down solenoid, the Transmitter STOP will only cancel the **FM•CONNECT** functions.

To use the Transmitter STOP button to cut the power supply, the following options should be considered:

WIRING OPTION B - (Page 8) - DC Electric Winches

A separate safety solenoid must be fitted between the power supply cable and the winch control solenoids. This can be a separate stand alone unit or it can be integrated within the winch solenoid control system prior to dispatch.

OPTIONS C & D -

Hydraulic Winches (Pages 9 & 10)

An electrically operated hydraulic dump valve must be included in the circuit. This can be a separate stand-alone dump valve or a section that is integrated into the winch electric control valve.

If a BHW Electric Control Valve system is being incorporated in the winch system, the **FM•CONNECT** Receiver can be pre-wired into the valve prior to supply.

Disconnecting the Power Supply

Disconnect the power connection to the winch control system. In the case of an electric winch turning off the isolator switch in the main supply cable will normally cut off the power supply to the solenoids.

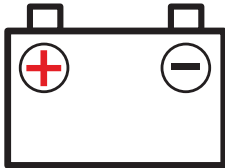

For hydraulic winches it will be necessary to disconnect the supply to the control relays on the electric or electric/pneumatic control valve. This can be done by removing the fuse in the supply line or disconnecting the positive supply to the control valve.

IMPORTANT NOTE: Do not re-connect wires to the electrical power supply until all connections have been made to the receiver and winch operating solenoids.

NOTE: if working close to vehicle batteries remember they contain flammable gases and can explode. Wear eye protection and avoid leaning over the batteries. Do not wear metal jewellery.

VEHICLE APPLICATIONS

Inside the Receiver Box

The wiring shown here is supplied as standard. The LED's are numbered, as they refer to recoding information shown on page 9.

IMPORTANT NOTE:

Depending on the wiring option chosen for the fit, please remember to insulate wires at the flying lead if they are NOT being used.

Wiring options selection see pages 5-8.

Mounting the Receiver

Select a suitable mounting position fairly high up in an open location in clear line of sight of the operating position. Ensure there is enough room to the left and above the Receiver to attach the antenna in a position that avoids damage. Secure the receiver through the mounting feet using 4mm bolts. (Not provided). Attach the antenna AFTER the Receiver box is fully mounted.

The electrical connections must point downwards and clearance should be provided to enable the connection to be made.

Key to Wires from the Receiver

Opposite is a guide to the wires contained within the Receiver cable. Use of some wires depend on wiring options selected.

Please terminate and insulate any unused wires.

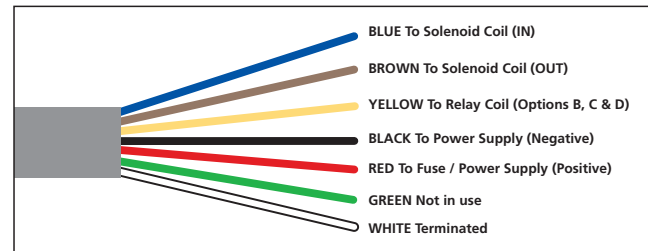
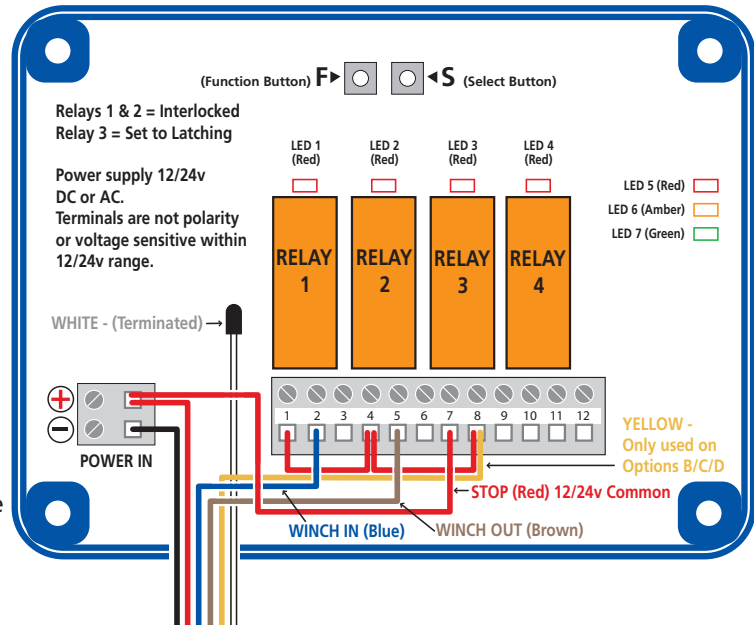

VEHICLE APPLICATIONS

WIRING OPTION A - Electric DC Winches Standard as Supplied

Route the cable and wire as shown below.

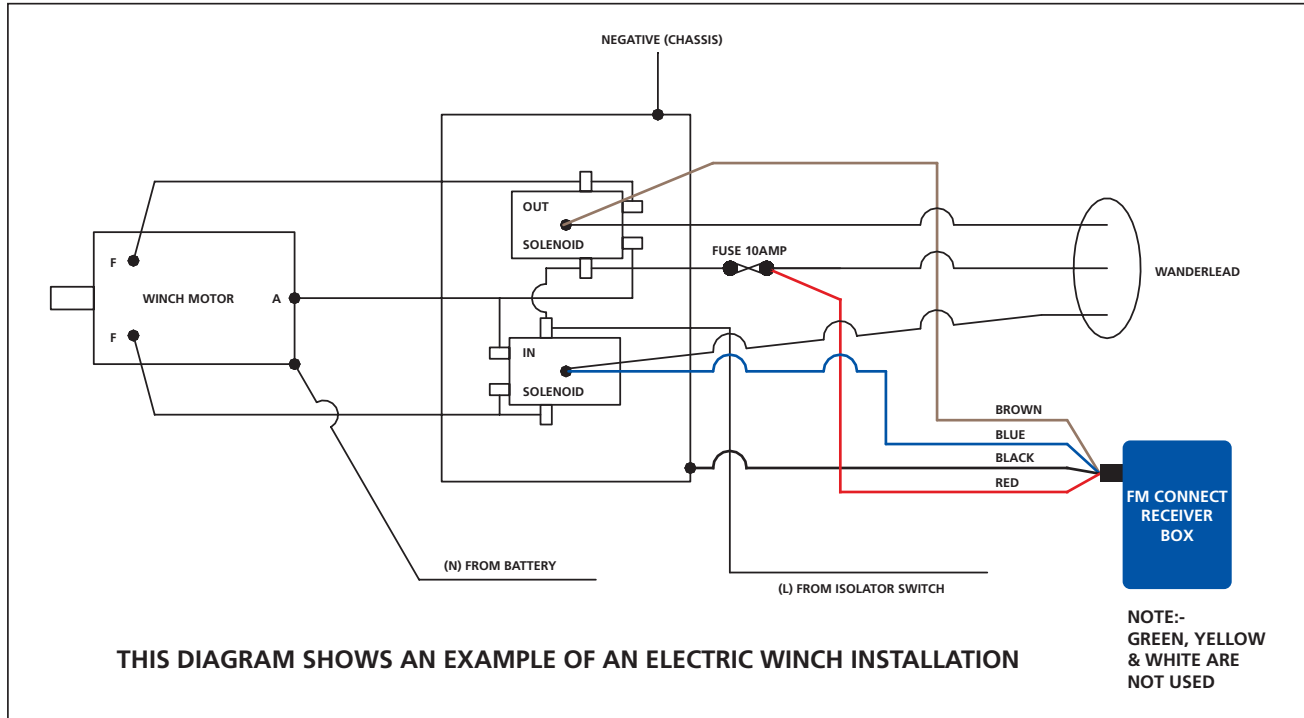

Please ensure wires unused from the Receiver box (Green, Yellow, White) with this option are suitably terminated and insulated.

VEHICLE APPLICATIONS

WIRING OPTION B

Electric Winch with Power Cut Off Solenoid (Utilising Part No. 4272 (12v) or Part No. 4273 (24v) Safety Relay Kits)

Route the cable and wire as shown opposite.

This diagram shows the utilisation of either the 4272 (12v) or the 4273 (24v) Safety Relay Kits. These are NOT included with the standard **FM•CONNECT** kit. They are sold separately. Contact BHW Group sales on 020 8953 6050.

***NOTE:** Green and white wires should always be insulated. If the safety solenoid is not used, the yellow wire should also be insulated.

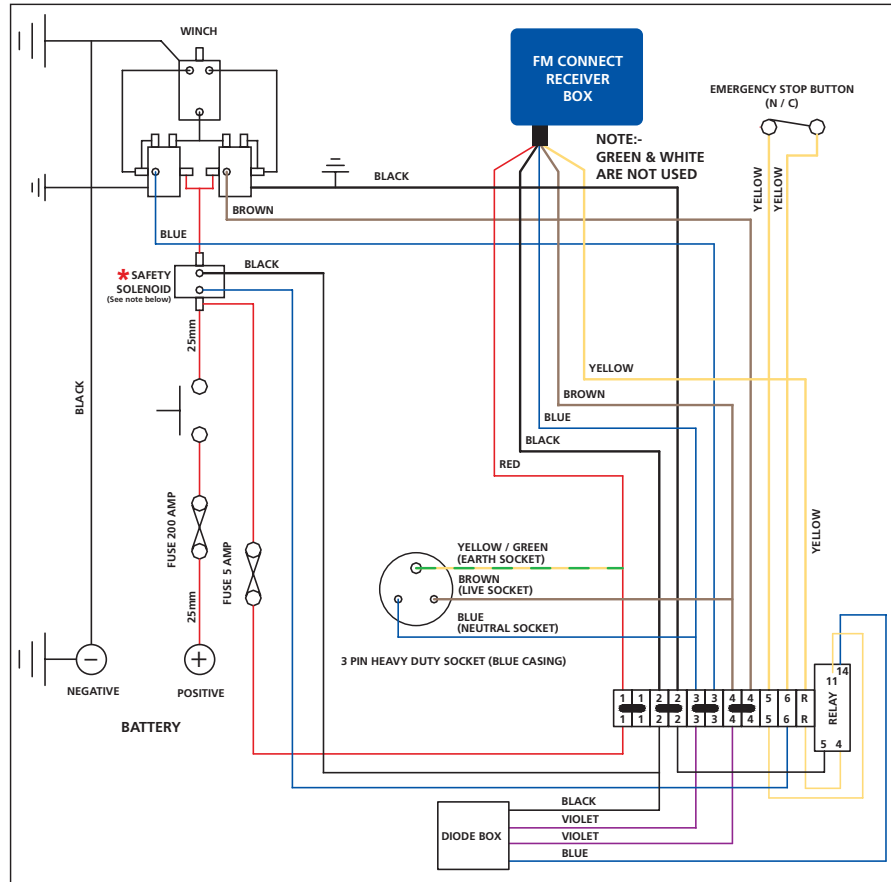

VEHICLE APPLICATIONS

WIRING OPTION C

Hydraulic Winch with Control Valve with Integral Vehicle Mounted Emergency Stop

Route the cable and wire as shown below.

NOTE: This diagram shows the BHW control system with integral dumping section. This is activated by the 'STOP' button on the radio transmitter, or by a separate Emergency Stop button fitted to the vehicle.

NOTE: Please ensure wires unused from receiver box (Green, White) with this option are suitably terminated and insulated.

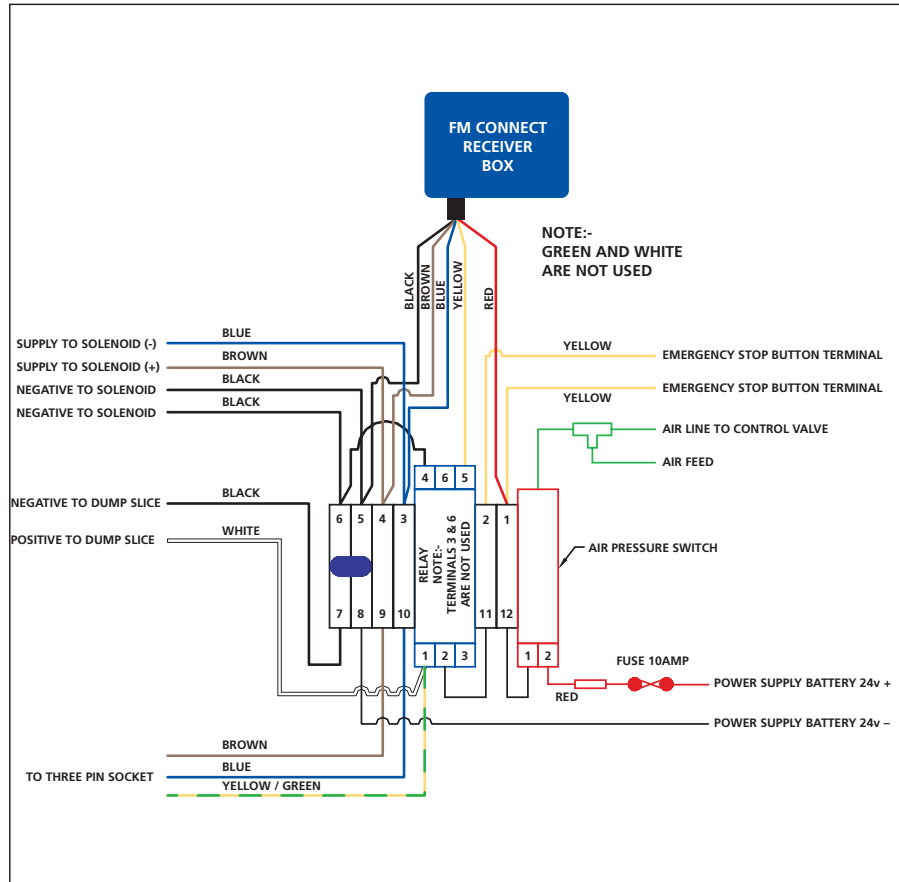

VEHICLE APPLICATIONS

WIRING OPTION D

Hydraulic Winch with Separate Dump Valve

Route the cable provided and wire as shown below.

This diagram shows connections to a separate dump valve.

A separate dump valve can be supplied (Part No. 10987 - up to 45 L/min, or Part No. 13584 - up to 159 L/min). Call BHW Group sales on 020 8953 6050.

To connect the Receiver cable and socket, line up the keyway on the plug with the socket and screw the knurled connector in place.

NOTE: Extra security can be had by inserting a switch and warning light into the vehicle's dash board which

will isolate the battery power supply to the Receiver. The switch can also be wired through the ignition which would ensure that all circuits are disabled when the vehicle is parked or left unattended.

Additional safety can be achieved by connecting the Receiver earthing wire to the vehicles hand brake warning light switch. This will ensure that the hand brake has to be 'on' whilst winching. Note: Some vehicle hand brake warning light switches do not go to 'earth'.

Please ensure wires unused from Receiver box (Green, White) with this option are suitably terminated and insulated.

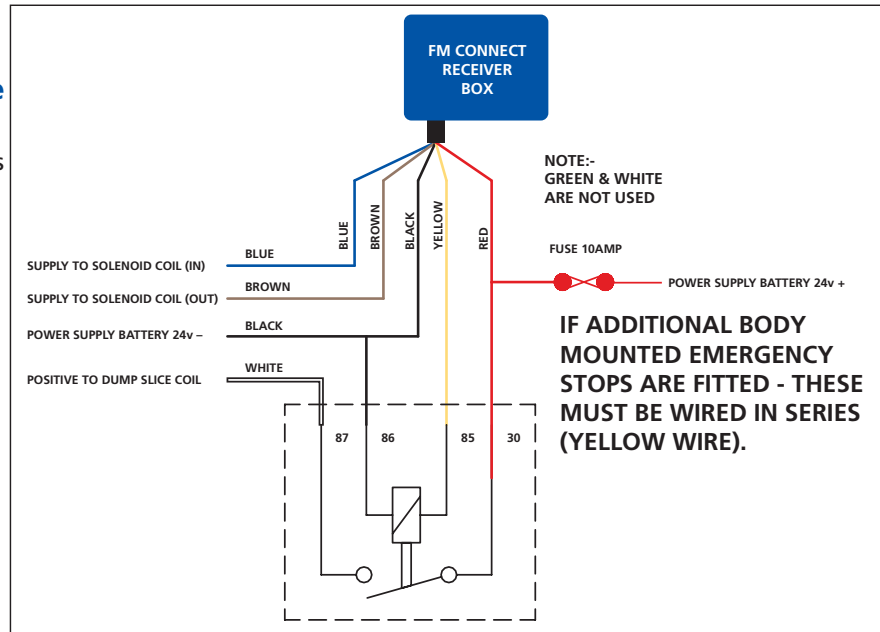

VEHICLE APPLICATIONS – Re-Connecting the Power Supply

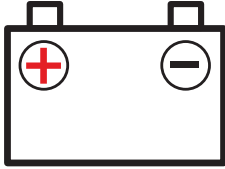

NOTE: if working close to vehicle batteries remember they contain flammable gases and can explode. Wear eye protection and avoid leaning over the batteries. Do not wear metal jewellery.

Re-activate power supply

NOTE: If at any time the electrical supply to the receiver is disconnected, no matter for how long, the receiver will still remember the coded Transmitter and function correctly when the supply is reconnected.

AC APPLICATIONS

WIRING OPTION E Suitable for 110/240v & 415v Applications

FM•CONNECT can be used to operate any electric control system provided the contactors are 24v AC or DC and that the controls are fitted with an isolator relay.

If **Winchmaster low voltage AC winch and hoist contols** are specified they are fitted with a 24v AC operated isolator relay, reversing contactors, thermal overload and transformer as standard and can be supplied with a load limiting device if required. Each control system has a 3m hand pendant incorporating In/Out buttons and an emergency stop.

continued...

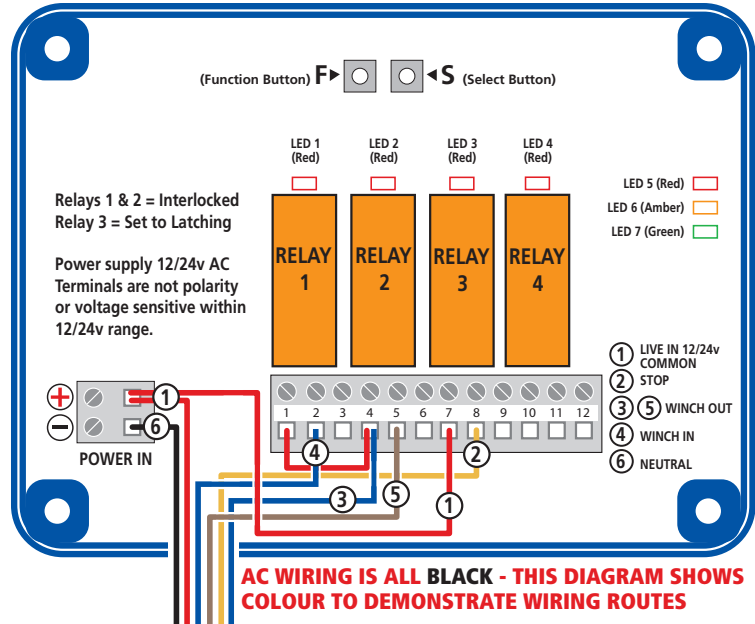

AC APPLICATIONS

If **FM•CONNECT** is ordered with the low voltage control system, the standard pendant is fitted with a plug. This enables the manual pendant to be removed from the main controls and the **FM•CONNECT** fitted in place. This allows total wire free control of the winch or hoist upto approximately 40 metres. **Note:** if longer operating distances are required other aerial options are available on request.

Installation details are as follows and must be carried out by a qualified electrician:

If **FM•CONNECT** is being retro fitted, make sure that the winch wire rope is extended 2-3 metres from the winch before disconnecting and unplugging the mains power. This is to ensure a working length of rope is extended to enable the **FM•CONNECT** to be tested **IN & OUT** after installation.

Locate the hand wired pendant control lead and cut this to leave a tail of approximately 300mm (or to suit the application) from the control box outlet. Install the 7-pin socket supplied with the **FM•CONNECT** by connecting the numbered wires to the corresponding numbered pins in the socket. Fit the 7-pin plug supplied with the **FM•CONNECT** to the remaining pendant control lead. Reconnect the pendant plug to the control system socket, turn on power and check that the winch and controls operate correctly with the modified pendant. If no problems are encountered, switch off and unplug the power cable and remove the pendant control.

Fit the **FM•CONNECT** receiver adjacent to the AC control box making sure that the plug fitted to the receiver will reach the socket on the AC control box. Connect the **FM•CONNECT** plug to the AC socket and reconnect the power supply. Press the radio control pendant stop button once; this will operate the isolator relay. Then press the up and down buttons alternatively to check that the winch or hoist drum rotates in the correct direction as indicated on the radio pendant.

AC APPLICATIONS

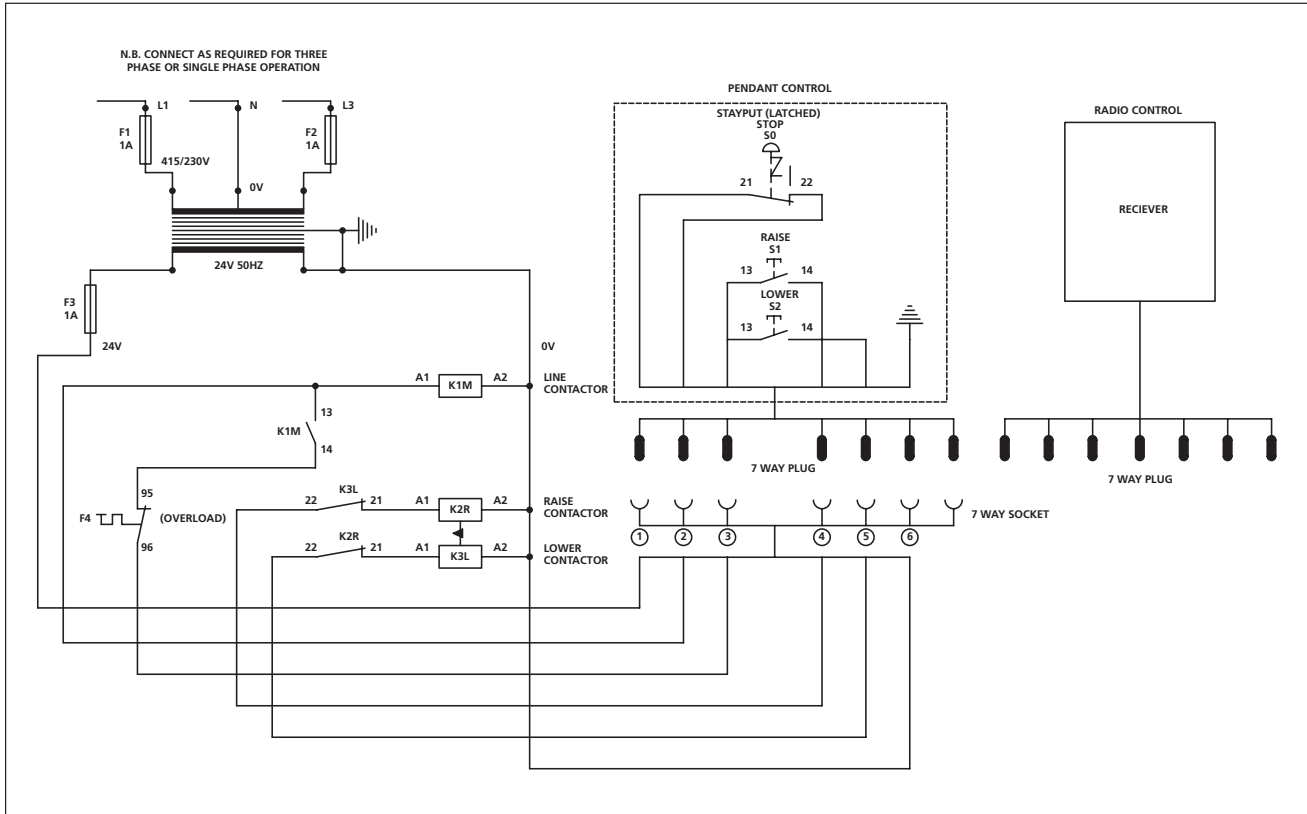

GENERAL INFORMATION

Coding the Receiver to a Replacement Transmitter

When the **FM•CONNECT** is supplied as a complete kit the Transmitter will already be pre-coded to the Receiver. If however, due to loss or damage, the Transmitter has to be replaced, the new Transmitter will have to be recoded:

Erasing the existing codes

First erase the original Transmitter codes programmed into the receiver as follows:

Remove front cover of the Receiver enclosure.

1. Press and release Function Button (F) once. LED 5 (Red) lights up.
2. Press and release Select Button (S) once. LED's 1,2,3,4 (Reds) light up. LED 4 (Red) stays on.
3. Press and hold Select Button (S) for 6 seconds, until ALL Red LED's go out.

Programming new codes

4. Press and release Function Button (F) once. LED 5 (Red) lights up.
5. Press and release Select Button (S) once. LED's 1,2,3,4 (Reds) light up. LED 4 (Red) stays on.
6. Press Select Button (S) TWICE, and immediately hold down ANY BUTTON on the TRANSMITTER until ALL the Red LED's above the Relays (1,2,3,4) go out (approximately 3 seconds). The Red LED 5 should flash twice. Transmitter buttons will operate the corresponding Receiver relays.

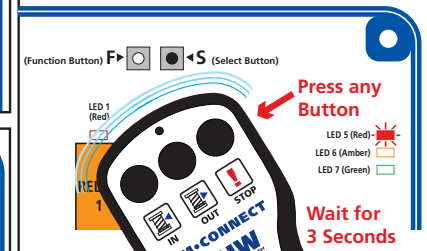
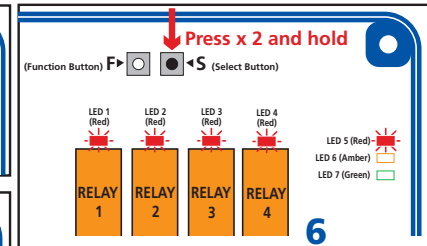
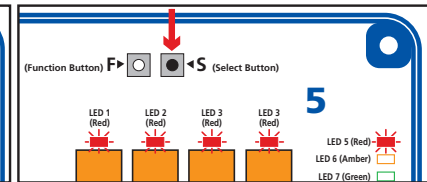
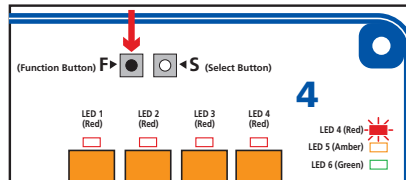
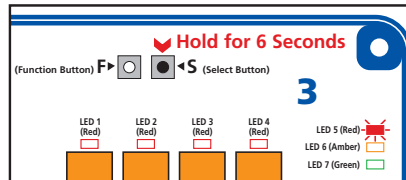
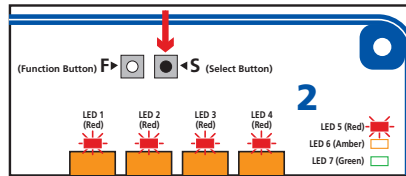
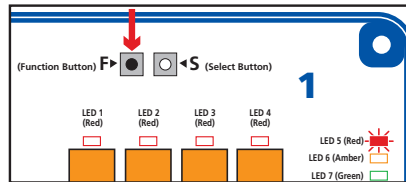

ERASING & REPROGRAMMING OF FM•CONNECT RECEIVER

PLEASE NOTE: Erasing programmes from the FM•Connect receiver will eradicate ALL programming. Erasing should only be carried out as part of a total reset of the receiver following a loss of functionality. Before doing so, check power supply and batteries in the transmitter as this may be the cause of loss of operation. Please follow instructions on the next THREE pages.

Erasing all programming

1. Turn ON the FM•Connect. Press and hold BOTH Function (F) and Select (S) buttons for more than 4 seconds.

All LED's will come on and go out when erasing has been completed.

Reprogramming the Receiver

2. Press and release Function button (F) once. Red LED 5 lights up.

3. Press and release Select (S) button once. LED's 1,2,3,4 light up and LED 5 stays on.

4. Press the Select (S) button twice and IMMEDIATELY hold down ANY BUTTON on the transmitter until all of the Red LED's above relays go out (approx. 3 seconds).

5. The Red LED 5 should flash twice.

6. Transmitter buttons will now operate the appropriate relays.

Please go to the next page to programme relays to 'Momentary' and 'Latched' switching modes.

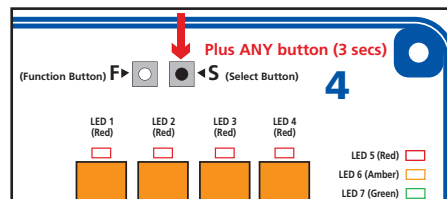
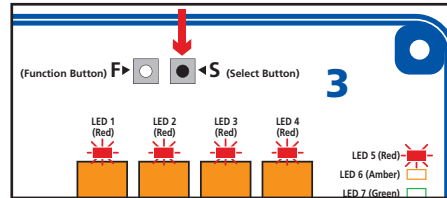
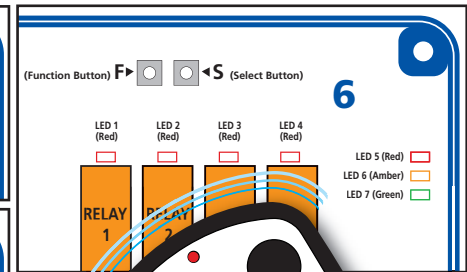
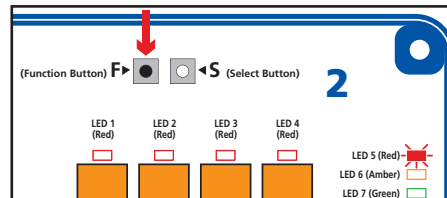
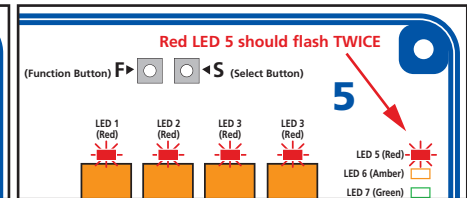
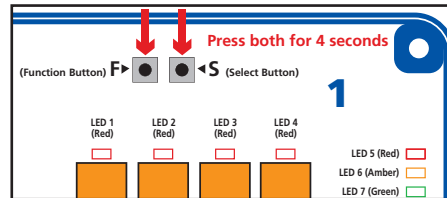

MOMENTARY AND LATCHED RELAY FUNCTIONS

MOMENTARY: Relay 1 (controls the 'IN' button on the transmitter) and Relay 2 (controls the 'OUT' button) both require a 'momentary' function, which means the activity selected only continues if the button on the transmitter is held down.

LATCHED: Relay 3 (controls the 'STOP' button) requires a 'latched' function, where the activity is started by pressing the button, and subsequently stopped by pressing the button again. (On/Off - like a light switch). Relay 4 is not used.

Programming - Momentary (Relays 1 & 2)

1. Press the Function (F) button twice. The Amber LED 6 lights up.
2. Press the Select (S) button. The Red LED above Relay 1 lights up. The Amber LED 6 should not be on. If it is, press the Select (S) button again to turn it off.
3. Press the Function (F) button again to move to Relay 2. The Amber LED 6 should not be on. If it is, press the Select (S) button again to turn it off.

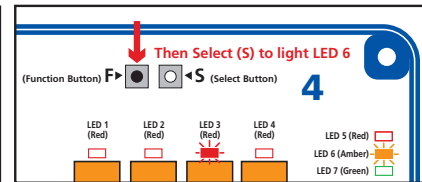
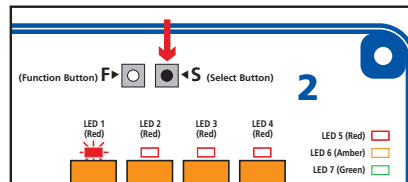
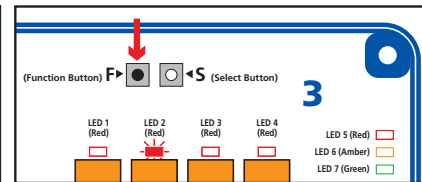
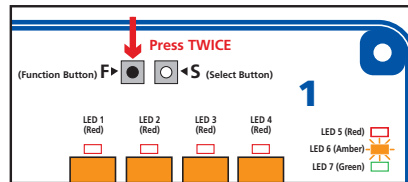

Programming - Latched (Relay 3)

4. Press the Function (F) button again to move to Relay 3. This time the Amber LED 6 **should** be on. If it isn't, press the Select (S) button to turn it on.

EXIT: To exit, press the Function (F) button when finished. In normal operations the Amber LED 6 will flash along with the Red (4) and Green (7) LED's to indicate successful programming of momentary and latched functions.

Please go to the next page to programme the **INTERLOCK** function. This function will ensure that activation of buttons on the transmitter are single commands and that activating more than one button at the same time is prevented. It is important that FM•Connect commands are protected this way, as simultaneous button use can cause circuitry problems.

PROGRAMMING THE INTERLOCK FUNCTION

INTERLOCK: Successfully programming the INTERLOCK function is an important protection mode for the receiver and transmitter. It will prevent simultaneous use of buttons on the transmitter that can possibly cause conflicting circuitry problems and disable operation features of the FM•Connect. It is important therefore that this programming is completed to prevent accidental misuse.

Programming - Interlock

1. Press Function (F) button THREE times, the Green LED (7) will light up.

2. Press the Select (S) button. The Red LED's above Relays 1 & 2 will light up.

3. Press the Select (S) button again. The Green LED (7) will again light up and the two Red LED's above Relays 1 & 2 will stay illuminated.

4 - EXIT: To exit, press the Function (F) button.

In normal operation the Green LED (7) will flash when the interlocking function has been activated, along with the Red (5) and the Amber (6) LED's.

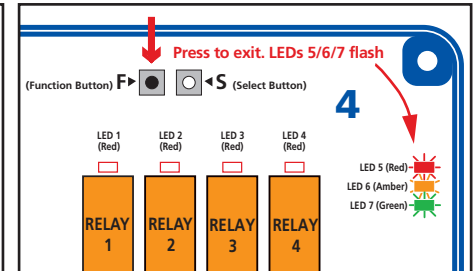
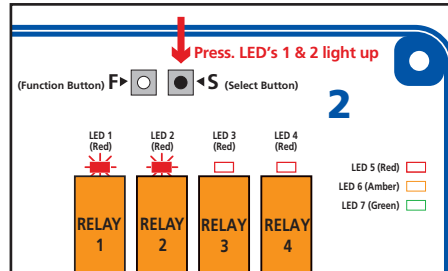
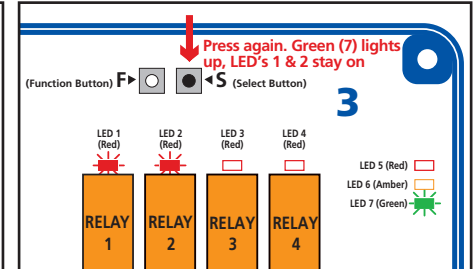
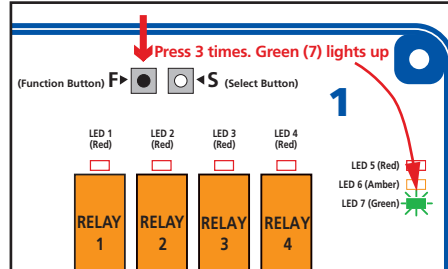

If you have any problems with recoding the FM•Connect, please contact the BHW Group sales engineers who will advise on best practice. Call +44 (0)20 8953 6050 or email: sales@bhwgroup.co.uk.

Transmitter Battery Replacement

Transmitters in new kits are already supplied with batteries, however they will ultimately need replacing.

To change the batteries:

Remove belt clip from back of Transmitter.

Unscrew plate located behind clip.

FM•CONNECT Transmitters require 3 x AAA batteries.

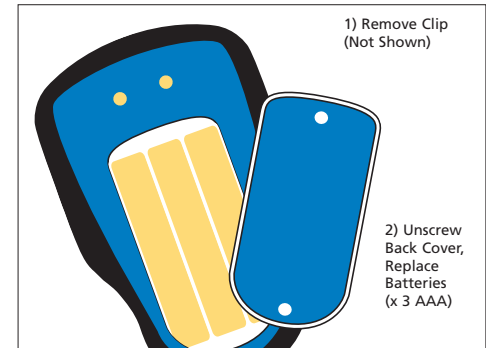

WARRANTY

FM•CONNECT is guaranteed for 12 months from the date of purchase. The guarantee is conditional on installation being carried out in accordance with our instructions. The winch must also be fitted with an isolation system to enable all power to switch off in the event of an emergency.

To comply with EMC Directive 95/54/EC the equipment should be inoperable when the vehicle is moving.

Under the Sellers Limited Warranties obligation set forth herein, the Seller shall not be responsible for incidental damages of any kind or for loss resulting from consequential damages to property, loss of profits and loss of use which may be caused by any fault in or malfunction, or failure of the **FM•CONNECT** System.

Warranty does not apply where the product has been tampered with or altered in any way, or where the serial number or date stamp has been defaced, altered or removed, or if in the view of BHW Group Limited the damage or failure occurred from misuse, negligence or accident.

BHW Group Limited reserve the right to change the design of any product without assuming any obligation to modify any product previously supplied.

BHW Group Limited reserve the right to change the design of any product without assuming any obligation to modify any product previously supplied. Equipment returned under warranty should be sent to BHW Group Limited service department at the Elstree address shown on the back page, with full name and address of sender, and a statement detailing the defect.

TROUBLE SHOOTING CHART

If the equipment does not work as it should, please check the points set out below.

The Receiver does not work when you are transmitting	The Receiver is connected incorrectly	Check the connection of the Receiver
	Incorrect operating voltage to the Receiver	Check the supply voltage
The Receiver's GREEN LED comes on when you are transmitting but the relays are not activated	The code in the Transmitter and the Receiver do not correspond, i.e. are not identical	Check the coding
The Receiver's GREEN LED does not come on when you are transmitting	The battery is dead	Replace battery
	The Transmitter is defective	Contact BHW support 0870 850 8989
The Transmitter's LED comes on when you are not transmitting	Somebody is transmitting in the vicinity on a similar frequency	Contact BHW support 0870 850 8989
The Transmitter's RED LED does not come on when you are transmitting	The batteries are dead	Replace Transmitter batteries
	The Transmitter is defective	Contact BHW support 0870 850 8989
The range is too short	Poor power supply	Replace batteries
	The antenna cables are damaged or incorrectly installed	Check the antenna

If you have followed the instructions supplied and still cannot get the FM•CONNECT system to work, please contact BHW Group support on 020 8953 6050.

EU DECLARATION OF CONFORMITY

We: **BHW Group Limited**

Hereby declare under our sole responsibility that the product described: -

NAME: **FM•CONNECT MK2** – MODEL: 2006

Is compliant with the following European Commission Directives; -

89/336/EEC as amended by 92/31/EEC

Low Voltage Directive 73/EEC as amended by 93/68/EEC
R&TTE 1999/5/EEC

Date: November 2011

Bushey Hall Winchmaster sales@bhwwgroup.co.uk www.bhwwgroup.com

Southern Office: Lismirrane Industrial Park, Elstree Road, Elstree, Herts, WD6 3EE Tel: +44 (0)20 8953 6050 Fax: +44 (0)20 8207 5308

Northern Office: 6 South Orbital Trading Park, Hedon Road, Hull, East Yorkshire, HU9 1NJ Tel: +44 (0)1482 223 663 Fax: +44 (0)1482 218 285

Bushey Hall Winchmaster is a division of BHW Group Limited. Registered in England No. 1342461



CERT. No. 1769

BHW

Bushey Hall Winchmaster
www.bhwgroup.com

Bushey Hall Winchmaster sales@bhwgroup.co.uk www.bhwgroup.com

Southern Office: Lismirrane Industrial Park, Elstree Road, Elstree, Herts, WD6 3EE Tel: +44 (0)20 8953 6050 Fax: +44 (0)20 8207 5308

Northern Office: 6 South Orbital Trading Park, Hedon Road, Hull, East Yorkshire, HU9 1NJ Tel: +44 (0)1482 223 663 Fax: +44 (0)1482 218 285

Bushey Hall Winchmaster is a division of BHW Group Limited. Registered in England No. 1342461



CERT. No. 1769