

Plant Hire companies and those involved in moving plant and machinery often require vehicles that will provide flexibility to ensure maximum vehicle utilisation with the least amount of effort and down time.

Beavertail gradients must now be no more than around 10° for loading some equipment so they are long and not ideal for carrying other equipment such as site huts.

The solution is **POWER•WEDGE**.



The clever system enables the bodybuilder to manufacture this sophisticated ramp system with the minimum design effort. The main components are proven and designed in such a way that the ramp length and wedge height required can be accommodated. The bodybuilder carries out the general construction of the ramps to suit the users particular requirements. The equipment supplied with the BHW **POWER•WEDGE** system includes all the hydraulic rams and control equipment, steel connecting assemblies and hinge bearing points.



POWER•WEDGE Double Folding Ramp System

POWER•WEDGE RAMP SYSTEM INCLUDES

- Hydraulic Rams-Nitrotec impregnated for protection against corrosion & stone chipping
- Controls for raising lowering and folding
- Double acting over-centre valves for safety
- System mechanism with all hinge points
- Manual locking
- Full fitting instructions
- Optional DC power pack
- Optional pneumatic locking with indicator light

FEATURES

- Bodybuilder fabricates ramps to suit customers application
- Easy to use controls with each ramp operated independently
- Will function on uneven ground
- Operators can obtain replacement parts quickly to minimise costly down time

POWER

- System uses the vehicles' hydraulic power if available. Alternatively an independent DC power pack can be supplied.

OPTIONAL EXTRA

FM•CONNECT REMOTE CONTROL SYSTEM – CONTACT SALES FOR DETAILS



Bushey Hall Winchmaster sales@bhwgroup.com www.bhwgroup.com

Southern Office: Lismirrane Industrial Park, Elstree Road, Elstree, Herts, WD6 3EE Tel: +44 (0)20 8953 6050

Northern Office: 6 South Orbital Trading Park, Hedon Road, Hull, East Yorkshire, HU9 1NJ Tel: +44 (0)1482 223 663

Bushey Hall Winchmaster is a division of BHW Group Limited. Registered in England No. 1342461 VAT No. 301 7915 80

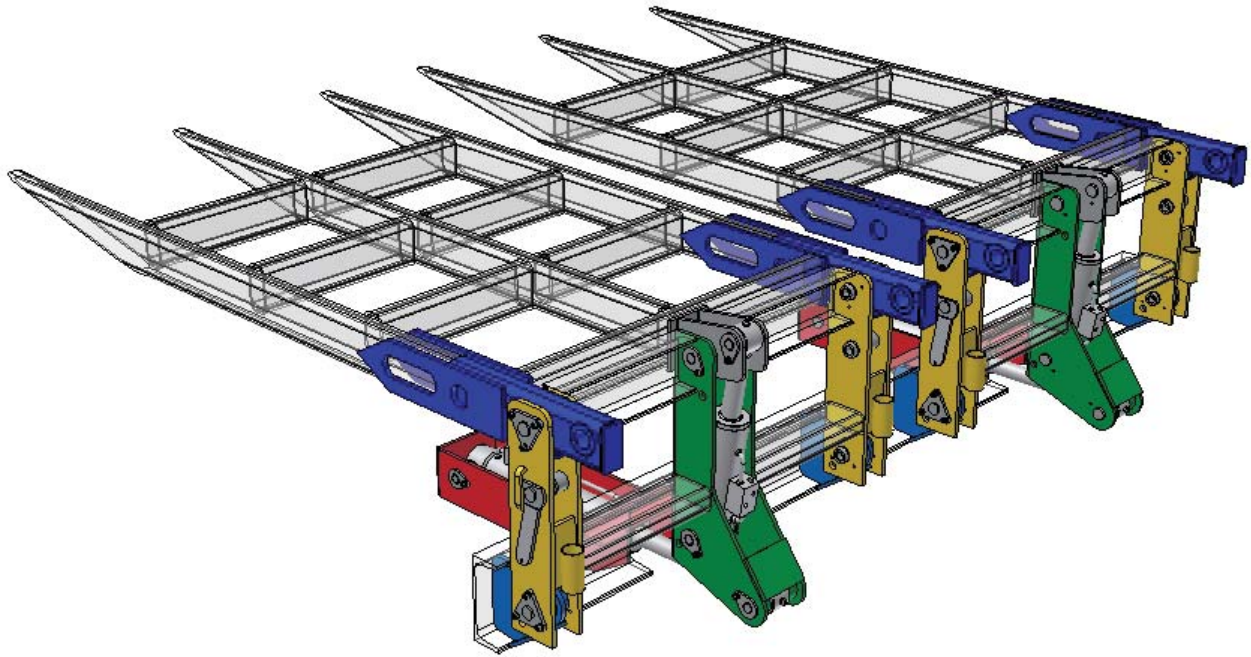

The **POWER•WEDGE Ramp System** includes the main component parts (shown in colour above) to allow body builders to construct two fully folding power wedge hydraulic loading ramps.

EACH KIT INCLUDES

- Hydraulic lifting and folding rams incorporating over-centre safety valves
- Ram mounting assembly
- Main lift reacting lever and folding assembly
- Ramp pivot lugs
- Ramp pivot pins
- All necessary pivot bosses
- Ramp locking pins
- Main lift ram pivot plates
- Hydraulic control valves
- Full fitting instructions
- Optional DC power pack



Bushey Hall Winchmaster sales@bhwwgroup.com www.bhwwgroup.com
 Southern Office: Lismirrane Industrial Park, Elstree Road, Elstree, Herts, WD6 3EE Tel: +44 (0)20 8953 6050
 Northern Office: 6 South Orbital Trading Park, Hedon Road, Hull, East Yorkshire, HU9 1NJ Tel: +44 (0)1482 223 663
 Bushey Hall Winchmaster is a division of BHW Group Limited. Registered in England No. 1342461 VAT No. 301 7915 80

