

FITTING & OPERATING INSTRUCTIONS



BHW WINCH•ASSIST SYSTEMS AMBULANCES & RESCUE VEHICLES

Motability & TUV Approved



Part No. 12957 / 07.02.23

Bushey Hall Winchmaster sales@bhwgroup.com www.bhwgroup.com

Southern Office: Lismirrane Industrial Park, Elstree Road, Elstree, Herts, WD6 3EE Tel: +44 (0)20 8953 6050 Fax: +44 (0)20 8207 5308

Northern Office: 6 South Orbital Trading Park, Hedon Road, Hull, East Yorkshire, HU9 1NJ Tel: +44 (0)1482 223 663 Fax: +44 (0)1482 218 285

Bushey Hall Winchmaster is a division of BHW Group Limited. Registered in England No. 1342461

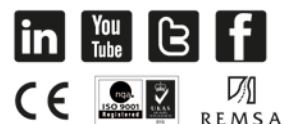

CONTENTS

INTRODUCTION	3
INSTALLER RESPONSIBILITY FOR CE COMPLIANCE	3
WINCH INFORMATION	
WINCH ASSIST MODELS & RATINGS	4
WINCH LABELS	5
INSTALLATION	
GENERAL INFORMATION	5
IN LINE MOUNTING	5
KIT PARTS	6
WIRING	7
OPERATING INSTRUCTIONS	
GENERAL NOTES	8
OPERATING THE WINCH	8
LOADING	9
UNLOADING	10
SAFETY – EMERGENCY STOP	10
AUTO CUT OUT / RESET OR FUSES	10
MAINTENANCE	
MONTHLY MAINTENANCE	11
SPARES	11
CARE OF THE ROPE & WEBBING STRAPS	11
WARRANTY	12

INTRODUCTION

PLEASE READ THIS MANUAL CAREFULLY BEFORE INSTALLATION OR OPERATION OF THE WINCH

Those responsible for the installation and the operation of this winch must read and understand this manual. The first section deals with the installation requirements and the second section is for the user and provides information to ensure safe use of the winch.

BHW Winch•Assist Winches are of the highest quality and have been designed to give a robust and efficient service for many years if care and attention are given at all times to correct installation, operation and maintenance.

PLEASE KEEP THIS MANUAL WITH THE WINCH.

INSTALLER RESPONSIBILITY FOR CE COMPLIANCE



1. Mount winch in accordance with instructions.
2. Install an emergency stop switch in accordance with instructions included in this manual.
3. Install the recommended webbing strap (or soft ropes if using a concealed winch system – see below) on to the winch drum with suitable connections for stretcher (or wheelchair) attachment.
4. Install a suitable auto cut out switch – which can be easily reset - to the live feed to reduce the possibility of overload. Auto cut out switches are available from the BHW Group, Part No.8303 (See Page 7).
5. Load test the winch following installation to check the integrity of the mounting and correct operation of the winch under load.

‘IN LINE’ MOUNTED WINCHES

In Line Mounted winches generally use webbing straps to connect the winch to the stretcher (or wheelchair).

CONCEALED WINCHES

Concealed winches offer the option of a soft rope fed through a tube to connect the winch and the stretcher (or wheelchair). This enables the winch to be mounted at right angles or offset to the line of pull.

Several options for mounting winches that can be concealed are available from the BHW Group.

BHW Winch•Assist systems must be installed correctly in accordance with the fitting instructions (Pages 6-8) and subsequently the installer and user must also adopt the correct procedures for operation (See Operating Instructions Pages 9-11).

It is important that with the winch installation adequate provision is made so that the load is transmitted into the floor pan of the vehicle. Strengthening plates should be used to spread the load where necessary.

WINCH INFORMATION

WINCH•ASSIST MOTORS FOR AMBULANCES & RESCUE VEHICLES

Winch Model 6 **Part No. 15104**

- Drum and gearing at 90° to motor
- Amperage Draw: 25amps
- Working Load Limit (Maximum pulling force in strap upper layer): 131kgf
- Line Pull - Bare Drum (30mm diameter): 200kgf
- Typical Rolling Load Capacities on Gradients:

Gradient	5°	7°	10°	12°	15°
Capacity (kg)	1500	1070	750	630	500
- Drum Torque - Motor / Gearbox rating: 45Nm (4.6kgfm)

Includes electric motor brake and all gears running in oil bath



Winch Model 6 / Two Speed **Part No. 12319**

- Two speed option enabling fast deployment of strap / attachment to the stretcher (Fail Safe)
- Drum and gearing at 90° to motor
- Amperage Draw: 25amps
- Working Load Limit (Maximum pulling force in strap upper layer): 131kgf
- Line Pull - Bare Drum (30mm diameter): 200kgf
- Typical Rolling Load Capacities on Gradients:

Gradient	5°	7°	10°	12°	15°
Capacity (kg)	1500	1070	750	630	500
- Drum Torque - Motor / Gearbox rating: 45Nm (4.6kgfm)

Includes motor brake and all gears running in oil bath

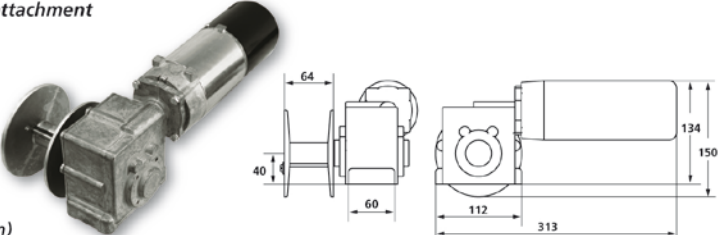

Winch Model 7 'Bariatric' **Part No. 12162** **LARGER LOAD CAPACITY**

- Heavier capacity winch - up to 1230kg on 12° gradient
- Drum and gearing at 90° to motor
- Amperage Draw: 25amps
- Working Load Limit (Maximum pulling force in strap upper layer): 256kgf
- Line Pull - Bare Drum (30mm diameter): 360kgf
- Typical Rolling Load Capacities on Gradients:

Gradient	5°	7°	10°	12°	15°
Capacity (kg)	2900	2100	1475	1230	1000
- Drum Torque - Motor / Gearbox rating: 88Nm (9.0kgfm)

Includes motor brake and all gears running in oil bath



WINCH INFORMATION

WINCH LABEL



WINCH MODEL INFORMATION

INSTALLATION

FITTING A WINCH•ASSIST SYSTEM - GENERAL

Ambulances from different manufacturers all vary in layout. The fitting instructions given are a general guide to best practice.

BHW Group can supply complete wiring looms. If BHW wiring looms are not being used, please ensure that electrical cables are the correct size. Winches may suffer voltage drop or be subject to slow running if cable specification is too small.

PLEASE FOLLOW THESE INSTRUCTIONS CAREFULLY AND CONTACT BHW GROUP IF ASSISTANCE IS REQUIRED.

WINCH MOUNTING – IN LINE

To mount an 'in line' Winch•Assist, it is recommended that a backing plate (not supplied) is fitted below the floor, of a suitable size, to ensure that the load is spread sufficiently across the floor pan.

Where floors are corrugated, it may also be necessary to fit an additional plate to provide an even surface for mounting the winch.

'In line' mounted winches should not be positioned on top of transmission tunnels.

An 'in line' mounted winch should be positioned so that the winch **drum** is directly in line with the direction of pull. It is the installers' responsibility to ensure that the unit is positioned so that the possibility of entanglement with the rotating drum is avoided.

Securely mount the winch by bolting down through the floor pan and any additional strengthening plates, into fixing holes using 4 x M6 high tensile bolts (min. grade 8.8) of a suitable length.

A suitable webbing strap can now be secured to the winch drum. In line mounted winches generally use a webbing strap which is clamped on to the drum spindle, although soft rope options are available.

INSTALLATION

KIT PARTS

Wanderlead



Part No. 13939

Wanderlead control with 3m flexible cable and jack plug.

Control & Emergency Stop



Part No. 6190

Additional control unit.

Emergency Stop, On / Off and Reset buttons.

Relay Pack 1



Part No. 6199

Relay pack with plug in connectors to reduce installation time.

Control & Emergency Stop



Part No. 14074

Mobility Vehicle Control Unit.

Emergency Stop, On / Off and Reset buttons.

Includes jack plug socket and resting bay for Wanderlead.

Relay Pack 2



Part No. 12175

Relay pack for 2 speed motors with plug in connectors to reduce installation time.

'Winch Out' Speed Control



Part No. 12173

For use with Model 6 Two Speed winch.

Control for higher speed on winching out web strapping, automatically resets when 'winch out' has stopped.

Wiring Looms with Plugs



3m = Part No. 10240
 7.5m = Part No. 6207
 9.5m = Part No. 8192
 10m = Part No. 6208

Connection looms with plug in connectors to reduce installation time between Relay Pack and Control / Emergency Stop.

Motor Filter

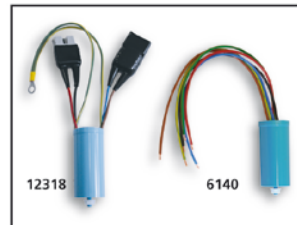

Part No. 12318

Winch Models: 6 (Single and Two Speed) & 7.

Part No. 6140

Winch Models: 1 & 2.

Motor filters for EU compliance with the EMC Directive.

16a Circuit Breaker / Reset

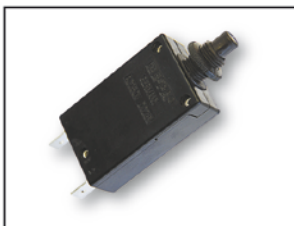

Part No. 7432

OPTIONAL EXTRA

16amp circuit breaker and reset switch, normally fitted under the dashboard.

Webbing Strap Stop

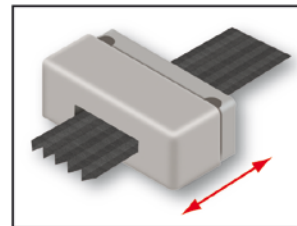

Part No. 11033

OPTIONAL EXTRA

Spring loaded electric pressure switch, to cut off winch control when webbing strap is fully winched in.



Extension for Wanderlead



Part No. 7758

OPTIONAL EXTRA

Coiled extension lead with jack plug and socket to add a further 2m+ length (fully extended) to Wanderlead.

INSTALLATION

WIRING – USING BHW KITS

PLEASE NOTE: The positive and negative supply from the battery and the red and black cables to the winch must be a minimum of 6mm² cross section to avoid any voltage drop. A minimum of 8v through the system must be maintained at the winch to release the brake (if fitted).

The motor filter must be fitted to comply with the EMC Machinery Directive, and suitably earthed to the chassis of the vehicle. The filter and the relay box should be located as close to the winch as space can allow.

BHW Winch•Assist systems should always have an auto cut out / reset in the wiring loom. The 16 amp auto cut out / reset button is linked into the positive supply from the battery and must be fitted to these systems. The auto cut out is normally mounted under the dashboard, or inside the bonnet, close to the battery for ease of access. Operators should be made aware of its location for access.

Additional external safety cut outs, wired from the relay box are optional. If you require more information, please contact our sales engineers at BHW Group (0208 953 6050) who will be pleased to advise.

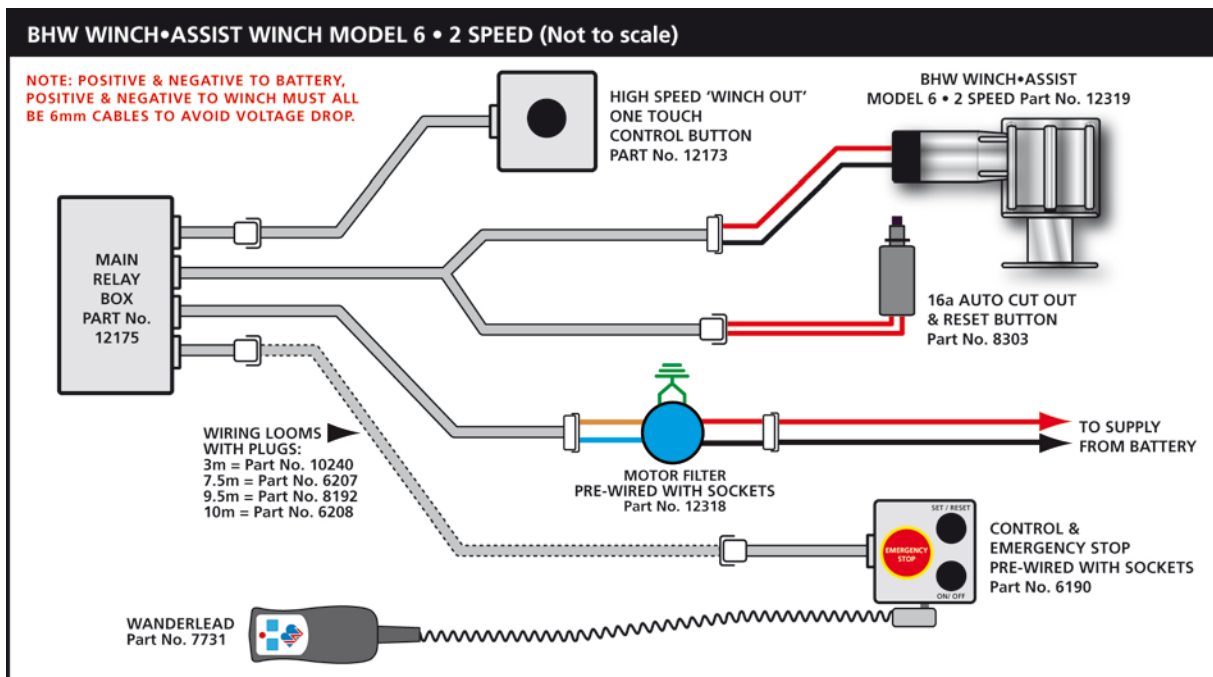
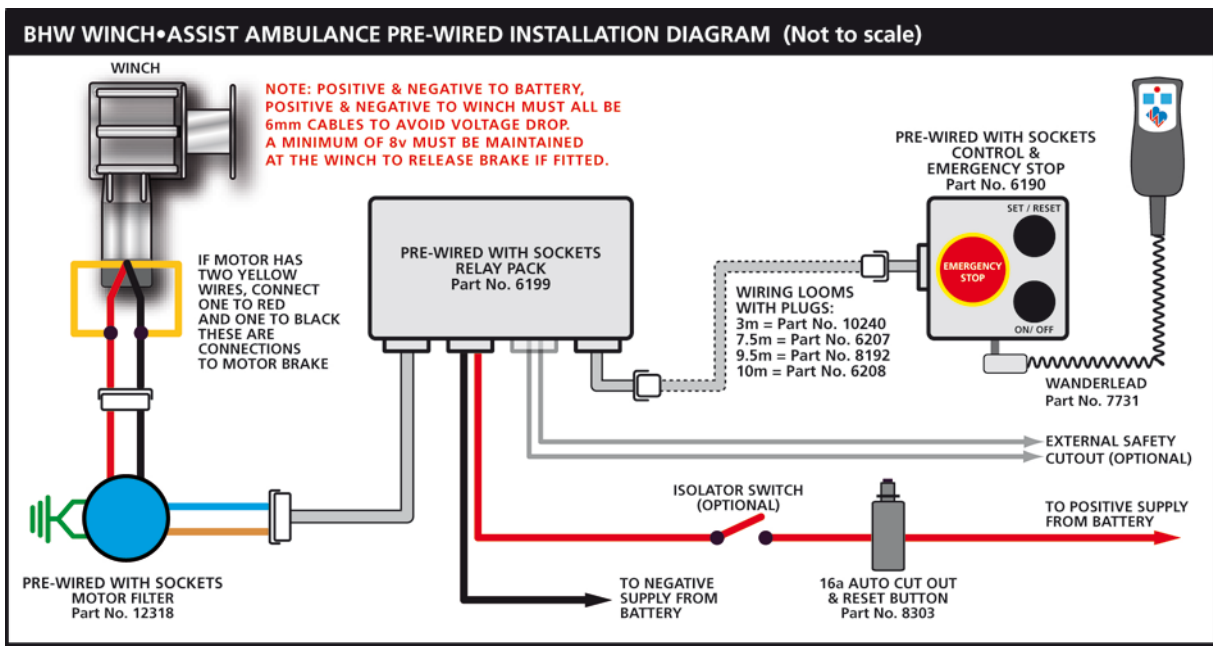

OPERATING INSTRUCTIONS

GENERAL NOTES

Once the BHW Winch•Assist has been installed and the circuitry has been checked, the installer should test load the winch to ensure that all aspects of the system are working correctly.

PLEASE NOTE: As with any other electrical device fitted to a vehicle, the BHW Winch•Assist will use additional amounts of vehicle battery power. It is important therefore that the battery is of a suitable strength and regularly charged to eliminate possible power drop. Where possible we recommend that the engine is kept running during operation of the winch.

BHW Winch•Assist winches should be operated by a competent person fully capable of navigating stretchers or wheelchairs and their occupants. We strongly advise that all operators should read the supplied operating instructions carefully and thoroughly so that the use of this Winch•Assist system is fully understood.

The operator(s) should undergo training in the use of this equipment without an occupant. It is advisable to apply a nominal weight on a stretcher or wheelchair to build confidence and skill with winch operation and stretcher / wheelchair control.

The Ambulance team should be fully aware of the position of the Auto Cut Out button for reset purposes and also the Emergency Stop control – which must be sited adjacent to the loading area – i.e. in the rear of the vehicle.

This equipment should only be used with a qualified operator in charge of the task.

BHW Winch•Assist is designed to aid the loading and unloading of stretchers or free rolling wheelchairs and their occupants and shall not be used for any other purposes.

The winch control shall be in the possession of the operator at all times during winch operations for loading or unloading.

When using the equipment at night, adequate lighting must be provided to enable the operator to clearly see the loading and unloading task.

All other personnel should be kept clear of the operation at all times.

The operator is advised to wear gloves during the operation of the winch.

TO OPERATE THE WINCH - TESTING

The installer should test the winch operation unloaded and then loaded with a weighted load (no occupant) by following the winching instructions detailed in 'Loading' on the following page. This will test the system response and performance.

From the Emergency Stop / Control box, usually positioned at the rear of the vehicle, the wanderlead is connected using the jack plug socket underneath the control unit.

The winch is operated by pressing the 'IN' or 'OUT' buttons on the handset.

The strap should be winched out and in under tension, applied by hand. Failure to do so may result in the strap tangling on the drum.

It is recommended that the winch is tested to a load rating of at least 110% of the rated capacity to prove the integrity of the installation.

The wanderlead should be stored safely to one side when not in use.

OPERATING INSTRUCTIONS

PREPARING TO LOAD

Check that the vehicle handbrake is fully engaged.

If an isolation switch has been fitted into the system, turn it on. Check that wanderlead is plugged into the control unit located at the rear of the vehicle.

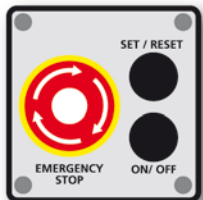

Prepare the winch and straps for the loading of the stretcher or wheelchair first. It is recommended that the strap is powered out from the winch **BEFORE** the patient is brought out into position as this will minimise exposure to the elements of the patient once outside.

Press the ON button and the SET button located on the control switch.

SINGLE SPEED UNITS

Use the wanderlead control plugged into the Controls / Emergency Stop console - and holding the strap gently under tension press the 'OUT' button on the wanderlead to power out the strap to the end of the vehicle ramp.

TWO SPEED UNITS



Press the high speed OUT button once on the separate switch (Part no. 12319) provided. Use the wanderlead plugged into the Controls / Emergency Stop console - and holding the strap gently under tension press the 'OUT' button on the wanderlead to WINCH OUT the strap towards the vehicle ramp.

This winching out process will perform at twice the regular speed. Once the wanderlead WINCH OUT control is released, (or the high speed button is pressed again) the high speed switch will revert to normal WINCH IN speed.

NEVER POWER OUT WITHOUT APPLYING TENSION TO THE STRAP, OR IT MAY TANGLE.

Do not further winch out if the chevrons on the strap are visible.

Ensure that straps are not tangled and clips are ready to use to connect to the stretcher.

Position the stretcher (or wheelchair) centrally in line with the ramp.

Connect the straps from the yoke assembly to the stretcher or wheelchair. Every stretcher or wheelchair brand is different in terms of manufacture, so trials should be undertaken with the stretcher or wheelchair empty to ascertain the best fixing points to ensure that the complete load is stable and balanced during the winching operation.

NEVER ALLOW THE STRAP TO FULLY UNWIND OFF OF THE DRUM – IF THIS HAPPENS, THE WINCH WILL WIND THE STRAP BACK ON THE DRUM THE WRONG WAY.

Attach the webbing straps to suitable anchor points on the load.

Operate the wanderlead 'IN' button to initially take up any slack and apply a slight tension. Disengage any brakes on the load and operate the wanderlead 'IN' button to fully load the stretcher or wheelchair.

The operator should safely guide the load into position when entering or exiting the vehicle.

When the load is fully winched into the vehicle, apply brakes. Affix travel restraints. Power out the strap slightly and remove the webbing straps from the load.

UNDER NO CIRCUMSTANCES SHOULD THE WINCH BE USED AS A LOAD RESTRAINT DURING A JOURNEY.

Maintaining a slight tension on the strap, power 'IN' any remaining strap length to safely store. Press the ON/OFF switch and safely stow the wanderlead. Turn off the isolator switch (if installed).

DO NOT DRIVE THE VEHICLE WITH THE WINCH ASSIST TURNED ON.

OPERATING INSTRUCTIONS

TO OPERATE THE WINCH - UNLOADING

After the vehicle has stopped and the handbrake is fully engaged, turn on the isolator switch (if fitted) and press the ON/OFF button on the winch control unit.

Retrieve the wanderlead from stowage and press the SET control button to activate the system. With the strap under tension, winch 'OUT' enough slack to allow connection to the load.

With the load still locked in position by its travel restraints, reconnect the webbing straps.

Take up any slack in the strap by carefully winching 'IN'.

Remove the travel restraints and disengage the stretcher or wheelchair brakes.

Ensure that the load is centrally positioned at the top of the ramp, ready for descent.

Press to wanderlead 'OUT' control and guide the load from the vehicle, down the ramp.

SAFETY

EMERGENCY STOP

In the event of an emergency press the EMERGENCY STOP button located on the winch control unit. This will immediately stop the winch.

Where possible, the load should be stabilised and secured until operation can safely continue.

To operate the winch again once any problem has been addressed, it is necessary to turn and unlock the EMERGENCY STOP button and press the SET button on the side of the winch control unit.

AUTO CUT OUT / RESET

If the winch is overloaded, it will trip the Auto Cut Out / Reset switch (Part no. 7432), **(This must be fitted to a Winch•Assist system)**. The Auto Cut Out can be reset by pressing the top button. Please ensure operators are aware of the location of this control for reset purposes.



16amp Auto Cut Out / Reset Part No. 7432

MAINTENANCE

REGULAR MONTHLY MAINTENANCE

Externally: The winch and winch area should be kept clean in order to prevent any build up of unwanted material on or around working parts.

- Check that WINCH IN and WINCH OUT are operating the right way round, as fully running out the rope may have reversed the operation. **This is important as it may cause safety features to fail if rope direction has been reversed.**
- Check the EMERGENCY STOP control to ensure it functions correctly by operating the winch and pushing the STOP button.
- Check winch for external damage.
- Check winch mounting for distortion and re-tighten mounting bolts if necessary.
- All external-moving parts should be lubricated with lightweight oil.
- All electrical connections and wiring should be inspected for loose connections, corrosion or fretting.
- Check vehicle battery power levels to ensure optimum operation.

SPARES

If it becomes necessary to obtain replacement parts, referring to the parts page in this manual, call BHW Group sales (+44 (0)20 8953 6050) and quote reference numbers.

CARE OF WEBBING STRAPS

It is most important that the webbing strap is inspected on a regular basis, for cuts, chafes and other damage. If damaged, the webbing straps should be replaced.

WEBBING STRAPS ARE NOT COVERED BY WARRANTY.

WARRANTY

BHW GROUP LIMITED warrants each new winch and ancillary equipment supplied against factory defects in material and workmanship for one year from date of purchase.

The responsibility for removing the winch or ancillary equipment is the owner's, together with its return, transportation prepaid to BHW Group Limited.

BHW Group Limited will, under this Warranty, without charge repair or replace at its option, parts, which on inspection are deemed to be defective. The loss of use of the produce, loss of time, inconvenience, commercial loss or consequential damages is not covered.

Warranty does not apply where the product has been tampered with or altered in any way, or where the serial number or date stamp has been defaced, altered or removed, or if in the view of BHW Group Limited the damage or failure occurred from misuse, negligence or accident.

THIS WARRANTY EXCLUDES WEBBING STRAPS OR SOFT ROPES

BHW Group Limited reserve the right to change the design of any product without assuming any obligation to modify any product previously supplied.

Winches or equipment returned under warranty should be despatched to BHW Group Limited service department at the address shown below, with full name and address of sender, and a statement detailing the defect and proof of purchase.



Service Department
BHW Group Limited
Lismirrane Industrial Park
Elstree Road
Elstree Herts WD6 3EE

Telephone: +44 (0)20 8953 6050
Email: sales@bhwgroup.com
Website: www.bhwgroup.com

WINCH•ASSIST – MODEL / KIT.....
SERIAL NUMBER.....
DATE OF PURCHASE.....