



**Lightweight, versatile chain hoists offering excellent performance for such compact machines.**

*These professional jobbing hoists are a 'must have' for all service vans.*

*Ideal for Civil Contractors, Builders and Factory Service Engineers.*

*Portable, saves time and effort - and a major contribution to maintaining Health and Safety standards on site.*

## OPTIONS

- **Chains are sold separately**  
*Lengths supplied to suit requirements and fall*
- **Chain bags**  
*Sizes available according to chain length required*

## LD 'JOBBER' SERIES DELTA CHAIN HOIST

### Light Duty Suspended Chain Hoists 500kg or 1000kg

Both available as 110v or 240v x 1ph AC

## FEATURES INCLUDE

- **Available in either 110v or 240v x 1ph options**  
*In the case of 110v version - via transformer*
- **Lightweight and compact design**  
*Easy installation, ideal for moving between different locations*
- **Safety slipping clutch**  
*Prevents hook becoming trapped into the hoist in the 'up' direction*
- **Supplied with chain bag**  
*For safe storage of chain - please ask about relevant capacities for length of chain required*
- **360° safety hook**  
*Self latching swivel type*
- **6 metre plug in pendant control**  
*2 button plus emergency stop*
- **5 metre power lead with commercial type 3 pin plug**
- **Limited motor draw on amperage**  
*Rectified brush type limits current draw to 6 amps. This enables hoist to operate from a standard 13amp ring main*

## ALTERNATIVE CHAIN HOISTS AVAILABLE

- **Suspension Hook - CTS Series** 500kg to 15000kg
- **Plain Trolley - CTY Series** 500kg to 15000kg
- **Motorised Trolley - CTD Series** 500kg to 15000kg
- **Geared Trolley - CTZ Series** 500kg to 15000kg
- **Lug Type Trolley - CTE Series** 500kg to 15000kg
- **Double Girder Trolley - CTH Series**  
500kg to 15000kg

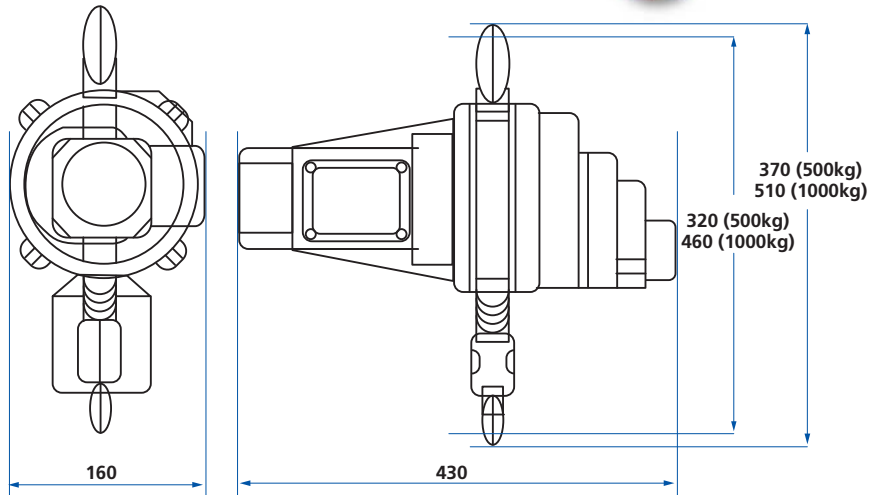
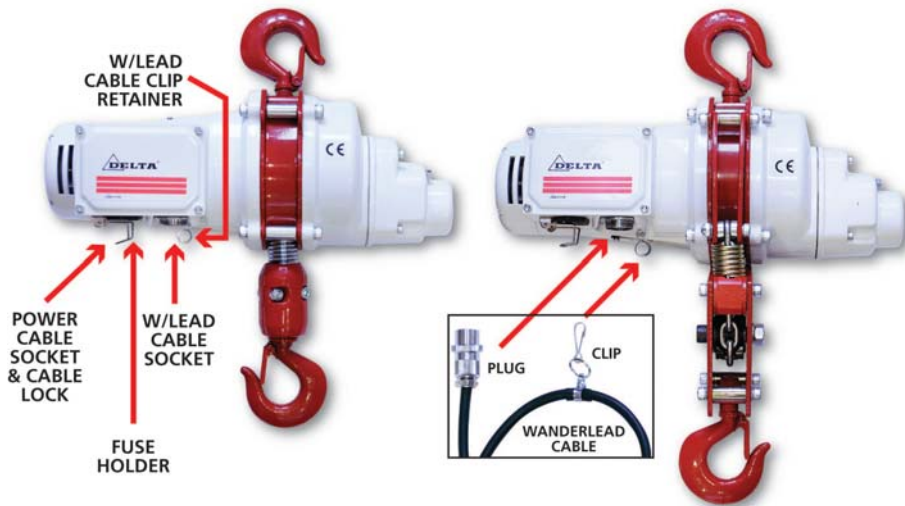

**SPECIFICATIONS**

**DU901**

**DU902**

		110v	240v	110v	240v
Lifting:	Capacity	500kg		1000kg	
	Height*	16m		8m	
	Type of fall	Single		Double	
Weight:	Hoist only	9kg		14kg	
	Total kit	20kg		24kg	
Line speed approx		6m/min		3m/min	
Outputs	Kilowatts	1.3kw		1.3kw	
	Amperes	12amp	6amp	12amp	6amp
Duty cycle		All have a duty cycle of 25%, with a maximum of 60 starts per hour			
Chain		Grade 80 HT galvanised - Links 6.3mm dia x 19.1mm long			

\* The lifting heights shown are the maximum using the standard chain storage bag. For further options please call sales.

**NOTES**

Please ensure that the fixing point for these hoists are capable of supporting the loads required.

These hoists must not be used for the movement of personnel.

Data shown is approximate and intended as a guide only.

**WARRANTY**

Each new hoist is guaranteed against defects in workmanship and material defects for a period of twelve months from date of purchase.

Chains are not included under warranty.

**Bushey Hall Winchmaster** sales@bhwwgroup.co.uk www.bhwwgroup.com

**Southern Office:** Lismirrane Industrial Park, Elstree Road, Elstree, Herts, WD6 3EE Tel: +44 (0)20 8953 6050 Fax: +44 (0)20 8207 5308

**Northern Office:** 6 South Orbital Trading Park, Hedon Road, Hull, East Yorkshire, HU9 1NJ Tel: +44 (0)1482 223 663 Fax: +44 (0)1482 218 285

Bushey Hall Winchmaster is a division of BHW Group Limited. Registered in England No. 1342461



CERT. No. 1769

WM25/16.08.11