

MAXPULL HAND WINCHES DUEL DIRECTIONAL CAPSTAN WINCH WITH LATCHING OR MECHANICAL BRAKE ME-5 – 500kg / ME-10 – 1,000kg



FEATURES INCLUDE

- Grooved Twin Drum Improving Friction
- Two Brake Options L or B (see options)
- Pressure Roller Secures Rope to Drum
- Stable Pulling Power in Two Directions
- Pull in a Choice of One or Two Directions
- Compact and Lightweight Design

EXAMPLE APPLICATIONS

- Factory Environments
- Movement of Heavy Machinery
- Agriculture, Farming, Greenhouses
- Furnace Trolleys with Controlled Speed of Operation
- Steeplejacks, Chimney Cleaning
- Opening/Closing of Silo Ports
- Opening/Closing of Gates
- Gymnasiums, Sports Centres



OPTIONS

B – Mechanical Brake

- Brake works when winch is in operation which makes it ideal for lifting but not for pulling.

L – Latching Brake

- Brake works when engaged. Whilst engaged the winch cannot be operated in either direction. Ideal for pulling, not to be used for lifting.

ADVANTAGES

The MAXPULL name is renowned for quality of design, finish and long-life durability:

- Grooved Drum and Pressure Roller System
- Units can be fully overhauled - see parts manual
- Melamine Resin Coating with Semi-Gloss Painted Finish

DIMENSIONS

FEATURED UNIT: MAXPULL ME-5 B

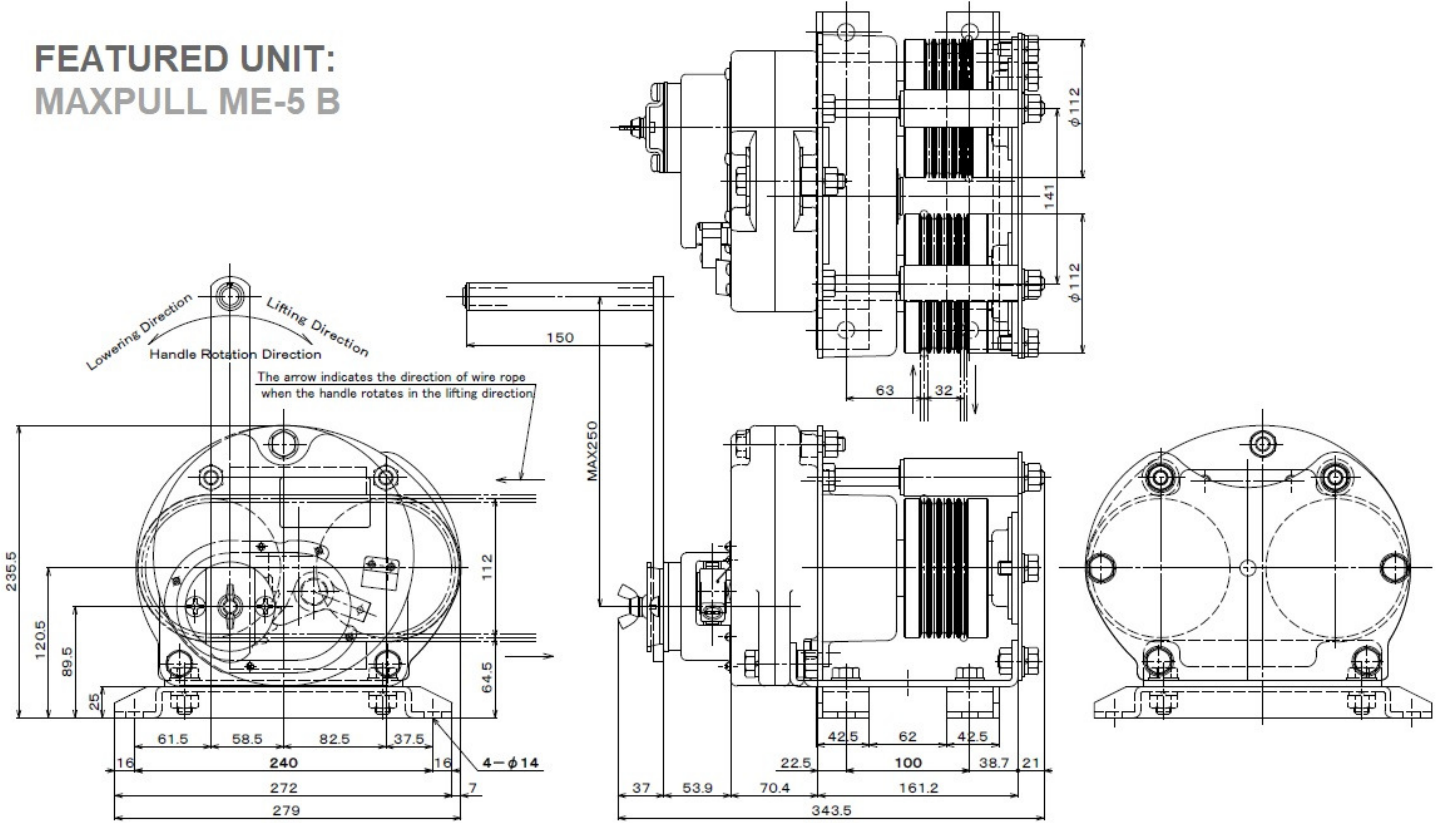

MODEL	WIRE ROPE	HANDLE FORCE (effective max)	GEAR RATIO	WEIGHT	WIRE ROPE TENSION	MINIMUM WRAPS ON DRUM
ME-5	4>6mm	97N (250mm)	1/13.3	30kg	4,900N	4
ME-10	8mm	114N (300mm)	1/19	30kg	9,800N	4

NOTES

These winches must not be used for the movement of personnel. 4 wraps of wire rope must be maintained on the drum. Data shown is approximate and intended as a guide only. You are strongly advised to carry out a risk assessment before selecting a manual winch for any proposed application.

WARRANTY

Each new winch is guaranteed against defects in the materials and workmanship for a period of twelve months from date of purchase.

Wire ropes are not included under warranty.

WM82/29.11.19

Bushey Hall Winchmaster sales@bhwwgroup.com www.bhwwgroup.com

Southern Office: Lismirrane Industrial Park, Elstree Road, Elstree, Herts, WD6 3EE Tel: +44 (0)20 8953 6050

Northern Office: 6 South Orbital Trading Park, Hedon Road, Hull, East Yorkshire, HU9 1NJ Tel: +44 (0)1482 223 663

Bushey Hall Winchmaster is a division of BHW Group Limited. Registered in England No. 1342461 VAT No. 301 7915 80

